

PROFRUIT MACHINERY

Official Manual & Instruction Document

Belt press

POWERPRESS 400/800/1200

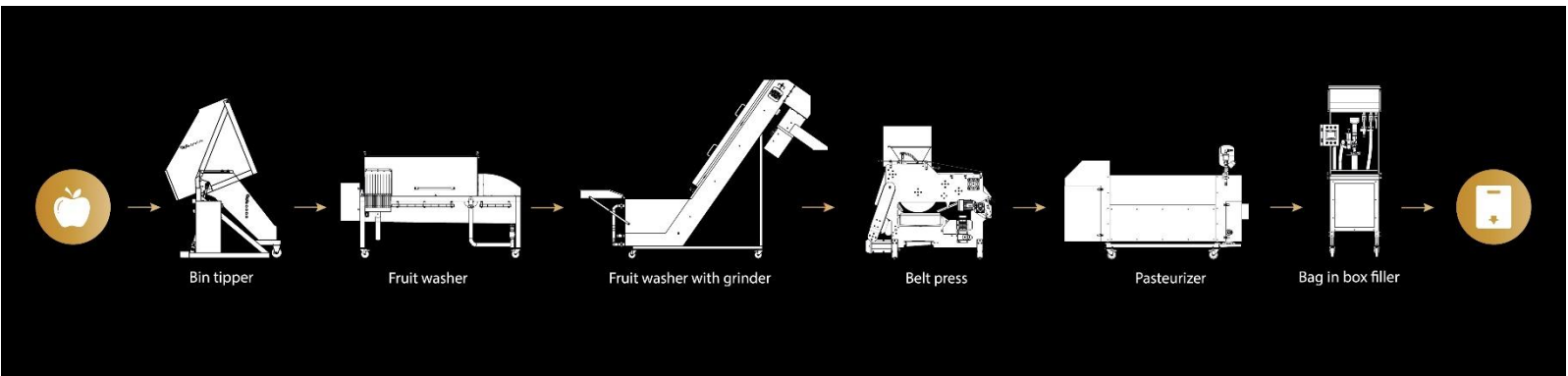

INFORMATION ABOUT MANUFACTURER

Manufacturer: UAB ProFruit Machinery

Representator: director Pijus Lopata

Address: Laugalių str.1A, Gargždai city, Klaipėda county, Lithuania

Company code: 305202037

VAT code: LT100012484812

E-mail address: info@pro-fruit.com

Website: www.pro-fruit.com

Warning signs

There are special warning and prohibition signs put on the machines which are meant to inform the user about danger and keep everyone – people and machinery – safe at all situations. The meaning of each sign is described below.

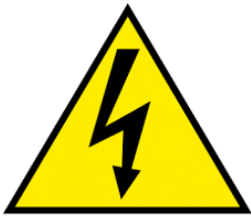

**Control console.
High voltage**



Headers required



Work shoes required



The risk of limb injury.

It is mandatory to remain alert and protect the limbs.



The risk of limb injury.

Moving parts of the machine.



**Hot surface.
Risk of getting burned.**



**Warning. Sharp parts of machine
Risk of limb injury.**

GENERAL REQUIREMENTS

General instructions:

- Ambient air temperature +8...+35° C.
- Relative humidity (when temperature +25 °C) iki 70%.
- Atmospheric pressure, kPa 84-107.
- The Law on Occupational Safety and Health of the Republic of Lithuania, the General Provisions and Safety Instructions for the Use of Work Equipment and the Laws on Occupational Safety and Health of the European Union must be observed while using the machine.

Belt press POWERPRESS

POWERPRESS is used for pressing fruit, berry and vegetable mash. The best efficiency of the belt press can be reached when pressing apples. Other fruits, berries and vegetables can also be used for processing, however, the juice, its quality and efficiency of the machine can differ, depending on each product. During the pressing process fruits, berries or vegetables enter the machine through the loading hopper, falls onto rotating belts and is pneumatically pressed by the cylinders. The pressed juice flows into collecting tray below the press. The pressing process is continuous.

Capacity: 400 kg/h, 800 kg/h ,1200 kg/h.

- The most exclusive and advanced feature of our POWERPRESS line is integrated pump and juice collection tank into the press itself. That means you save money and do not need additional juice collection tank and pump which otherwise would use much space and money.
- There is a filtration sieve integrated into the juice collection tank, so the juice is being filtrated even during the pressing stage providing cleaner and purer product.
- The belt press - contact surfaces are constructed from stainless steel or food-grade materials.
- Mounted on adjustable feet.
- High-pressure washer is included.
- There is integrated pump.
- Belt tension is adjustable.
- Easy to clean with no closed or inaccessible spaces, all parts are easy to assemble.
- Pneumatic lifting of the security cover of the press ensures easier access when cleaning.
- Cleaning of belt with high-pressure cleaner, scraper.

Attention! It is mandatory to wash off the device before starting it for the first time.

It is important to eliminate any manufacturing residues and the dust which has built up on the surface, taking care not to wet the electrical parts and keeping the power supply cable disconnected.

Machinery specifications and drawing

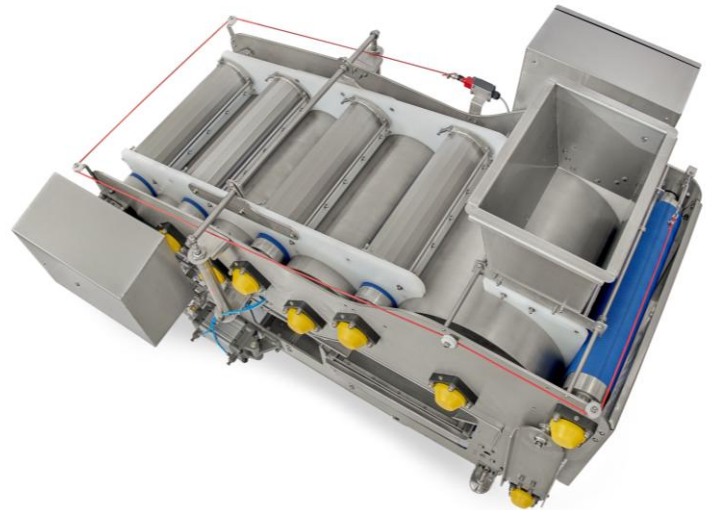

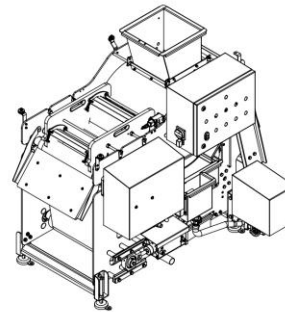
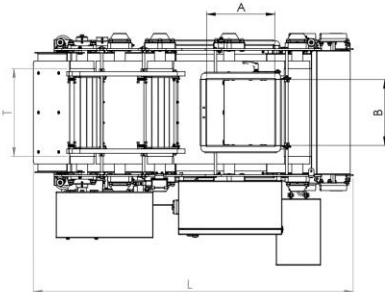
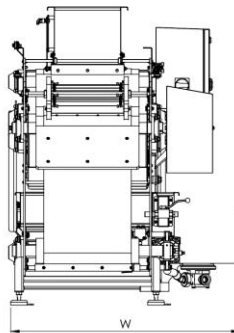
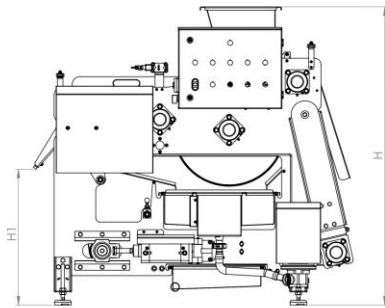

	Machine	Belt press
	Type	POWERPRESS 400

Output	kg/h	400
L	mm	1470
W	mm	1050
H	mm	1360
H1	mm	620
T	mm	400
AxB	mm	310x300
Supply source	kW	1.1
Supply voltage	V	3/N/PE ~ 400 V 50Hz

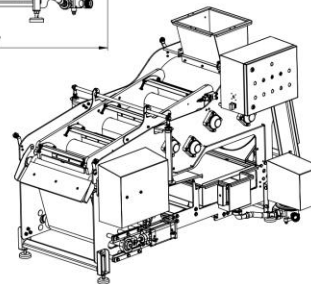
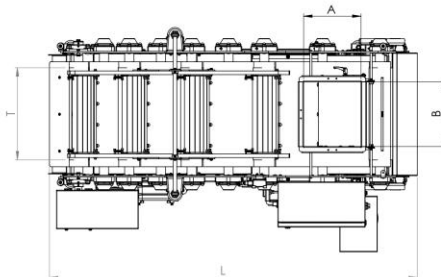
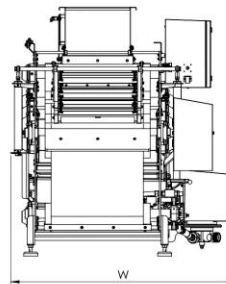
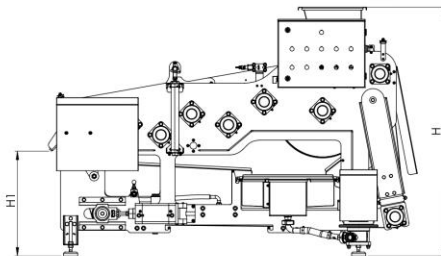

	Machine	Belt press
	Type	POWERPRESS 800

Output	kg/h	800
L	mm	2010
W	mm	1225
H	mm	1350
H1	mm	570
T	mm	500
AxB	mm	310x350
Weight	kg	650
Supply source	kW	1.5
Supply voltage	V	3/N/PE ~ 400 V 50Hz

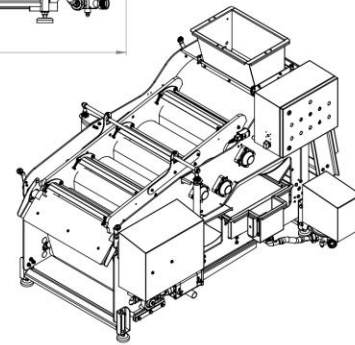
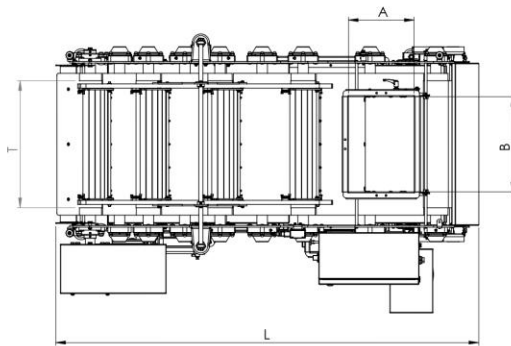
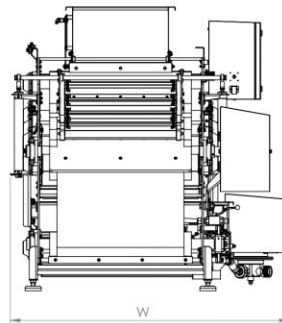
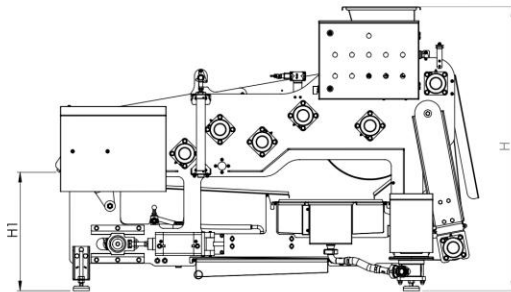

	Machine	Belt press
	Type	POWERPRESS 1200

Output	kg/h	1200
L	mm	2050
W	mm	1325
H	mm	1340
H1	mm	560
T	mm	600
AxB	mm	310x450
Weight	kg	720
Supply source	kW	1.5
Supply voltage	V	3/N/PE ~ 400 V 50Hz

Main components of machine

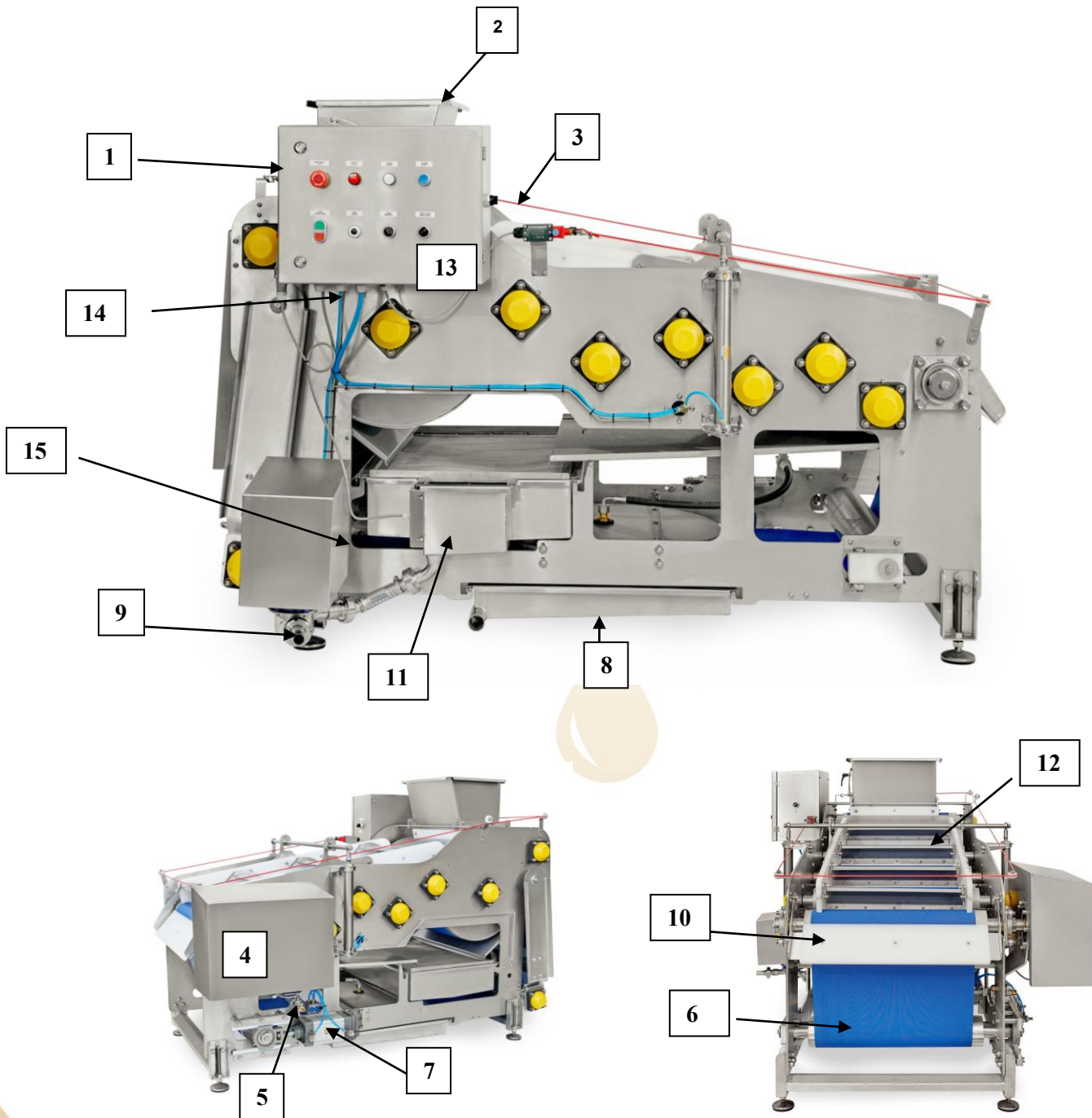

LIST OF COMPONENTS

1.	Electric cabinet
2.	Loading hopper with fruit mash inlet adjuster
3.	Safety circuit
4.	Main engine
5.	High pressure washer inlet and belt washer
6.	Belt
7.	Pneumatic belt adjuster
8.	Wastewater collection tray
9.	Juice transfer outlet
10.	Pressed mash leftover tray/scrapper
11.	Juice collection tank
12.	Plastic cover and scrapers
13.	Belt tension and pressure reducer valves (Inside el. Cabinet from 2022)
14.	6mm air pressure inlet
15.	Belt positioning safety sensors

EI. Cabinet control

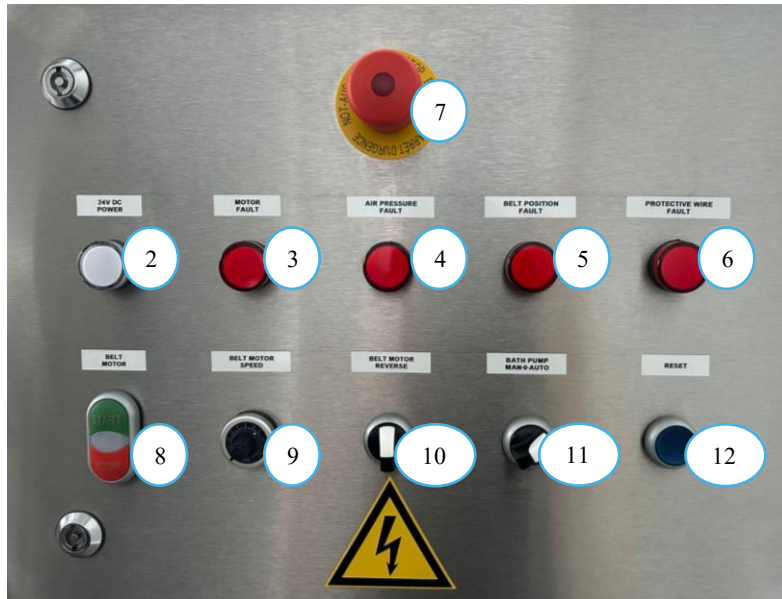

1.1 Fig.

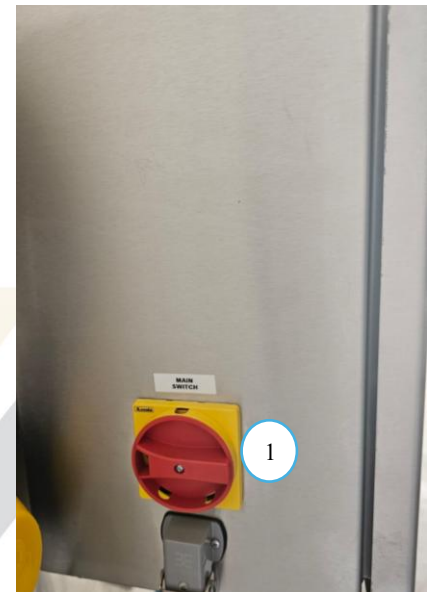

1.2 Fig.

- Control the **MAIN SWITCH (1/1.1 Fig.)** to turn the machine on or off. Horizontal position (0) means the machine is off, vertical position (I) means the machine is on.
- The button **24VDC POWER (2/1.1 Fig.)** shows voltage and is always lit when the machine is on.
- In case of engine failure, the light **MOTOR FAULT (3/1.1 Fig.)** lightens up in red color.
- In case of lack of air pressure failure, the light **AIR PRESSURE FAULT (4/1.1 Fig.)** lightens up in red color.
- In case of belt moving out of its place failure the light **BELT POSITION FAULT (5/1.1 Fig.)** lightens up in red color.
- In case of protective wire failure, the light **PROTECTIVE WIRE FAULT (6/1.1 Fig.)** lightens up in red color.

- In case of emergency or in the need of immediate stop, press **EMERGENCY STOP (7/1.1 Fig.)** button which is for emergency stopping. To turn this button off you need to pull the button back.
- In case of disturbing **FAULT or EMERGENCY STOP** lights you will need to fix the occurred problem and then press **RESET** button before starting to work again.
- To start or stop the press **BELT MOTOR (8/1.1 Fig.)** button **START/STOP**.
- To start or stop belt washer open/close the high-pressure washer inlet valve **(No.5)**.
- The speed of the tape can be changed using an adjusting **BELT MOTOR SPEED (9/1.1 Fig.)** wheel
- For belt to turn into reverse mode switch and hold button **BELT MOTOR REVERSE (10/1.1 Fig.)**. This button can be used when objects entry the press.
- The turning switch **BATH PUMP MANUAL/0/AUTO (11/1.1 Fig.)** controls if the pump should be in **MANUAL** (left) - **0** (center) **OFF – AUTOMATIC** (right) modes.
- When errors are displayed on the panel and the press does not start, press and hold the "Reset"**(12/1.1 Fig.)** button for 3 seconds. If the errors become inactive, the „Reset" button should no longer be lit.

Assembly, connection and installation of the machine

Steps to accomplish in order to start working with the machine:

- After placing the machine in its position, adjust the press level with a spirit level. **See page 22 for press level adjustment.**
- Connect power cable to the three-phase connection.
- Connect air compressor with 6mm tube air pressure inlet. Minimum air pressure – 5 bar. maximum pressure 6 bar. The air connection is located under the electrical shield at the bottom.

- Connect high-pressure washer to water inlet and turn the handle into horizontal working position. Connect water to high pressure washer and turn it on.

Instructions for using the machine

- Turn the **MAIN SWITCH** into the working mode – vertical position (I).
- In order to start work press the button **BELT MOTOR START** button.
- To start belt washer, open the high pressure washer inlet valve (**No.5**). Always be sure that water is connected to high pressure washer.
- Turn **BATH PUMP MANUAL/AUTO** by turning it right or left and choosing manual or automatic mode.

Safety mechanisms

- **EMERGENCY STOP** – needs to be pressed in case of emergency in order to immediately stop the machine.
- **Safety in case of a sudden black-out** – when the power supply is suddenly cut off or a similar situation happens the machine is turned on normally and does not cause any dangerous situations like sudden start or improper operation.
- **Stability of machine** – the machine has stable and strong legs which keep the machine in one position and does not move.
- **Safety of electronical pieces** – all the electronical pieces are installed in the internal part of the central electric cabinet and shielded with the protection lid. The lid can be opened only with a special key which is attached to the main cable of machine.

- PROTECTIVE WIRE** - the press is surrounded by a safety cord which stops the press when disturbed. This prevents accidental touching or leaning on the machine as well as accidental entry into the press of other objects. If the machine is not starting, check the red safety circuit switch. It has always to be pulled up and the marking should be in green color for the machine to work. After this is done press RESET and start the machine again.

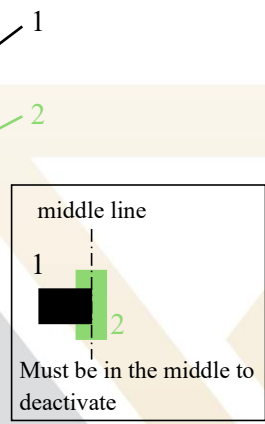
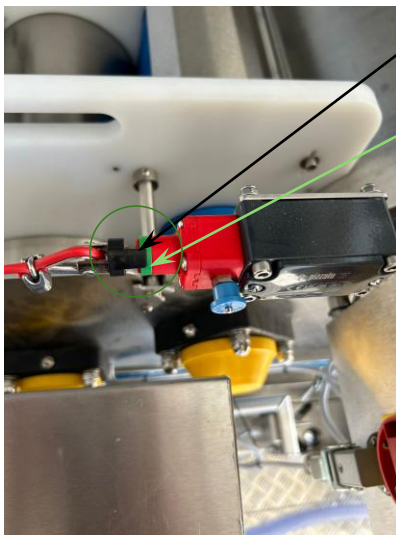

1.3 Fig.

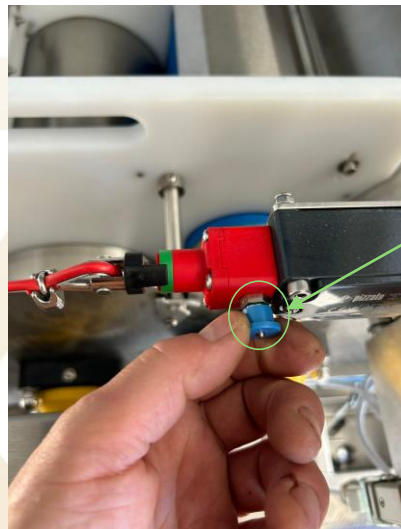

1.4 Fig.

1. Protective wire switch is activated.

2. Pull the blue button to deactivate it.



1.5 Fig.

3. Protective wire switch is deactivated.

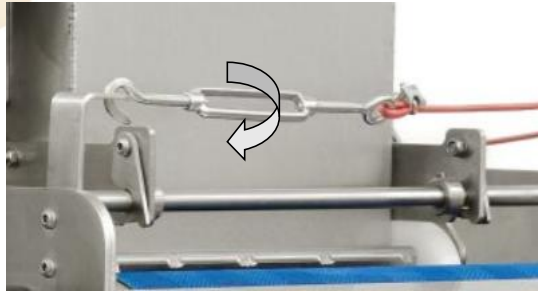

1.6 Fig.

4. Switch does not fixate – tighten the wire with screw. As in the picture, it would be in the center (1.3 Fig.).

The workplace of operator

- The machine is operated by one person.
- The workplace of the operator differs.
- When operating the machine, the operator works by the el. Cabinet.
- When the ready-to-press products or mash are loaded into machine the operator works by the press loading hopper.

Adjusting the belt

The belt can be adjusted manually or in working mode automatically by the pneumatic belt adjuster.

Setting the air pressure

To set the air pressure, it is necessary to complete the following steps:

- Turn on the compressor.
- Connect the compressor to the compressor inlet valve.
- The cylinder bellows will start to tighten the belt.
- The normal pressure for the press belt is around 2-3 bar. (1/1.7 Fig.). In order to adjust, pull and turn the pressure valve to set the correct pressure.
- The pressure reducer valve (2/1.7 Fig.) must always be set at range 5 - 6 bar. It is recommended to maintain a pressure of 6 bar. In order to adjust, **pull** and **turn** the pressure valve to set the correct pressure.

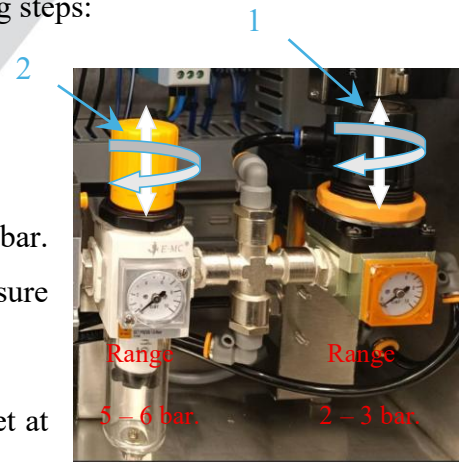

1.7 Fig.

Removing the scrapers

In order to remove the scrapers and separate them from the shafts it is necessary to unfasten the holding mechanism on both sides and remove the tension springs from the front of holders. Then the belt holders can be lifted from the press.

On POWERPRESS 400:

1. Unfasten the 4 holders on both sides.
2. Take out the whole cover for washing.



1.8 Fig.



1.9 Fig.

On POWERPRESS 800, 1200:

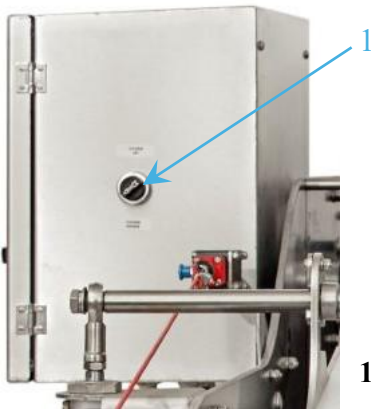

1.10 Fig.

4. Switch for lifting the scraper table (1/1.10 Fig.).

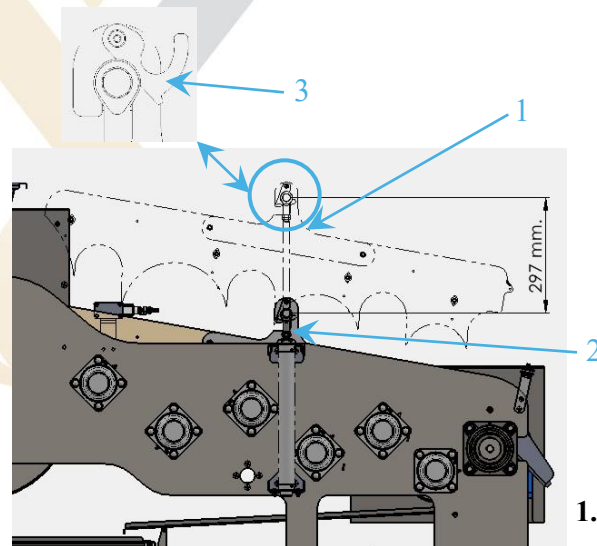

1.11 Fig.

1. Raised scraper table (1/1.11 Fig.). Lowered scrapers table (2/1.11 Fig.). Unfasten (3/1.11 Fig.) the 2 holders on both sides to remove the scraper table.

On POWERPRESS models – 400, 800, 1200:



1.12 Fig.



1.13 Fig.

1. Unfasten two holders on each scraper.

2. Gently remove the springs.

Removing scraper:

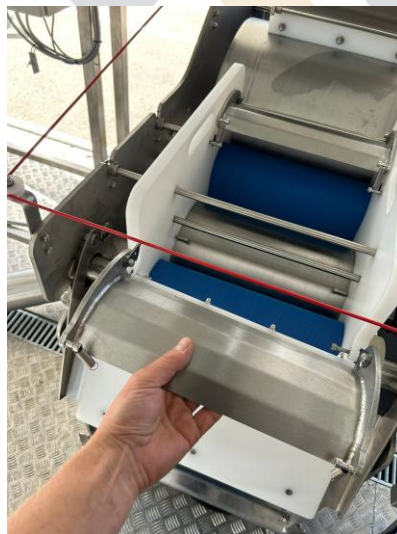

1.14 Fig.

3. Take out each scraper for washing.

Adjusting the inlet of the loading hopper

If necessary, the inlet of loading hopper can be adjusted by pulling the handle and adjusting the hopper manually. Maximum closure (**1.15 Fig.**) and maximum opening (**1.16 Fig.**).



1.15 Fig.



1.16 Fig.

The washing of machine

- Washing of machine is recommended to be done from the top to the bottom. First of all stop the machine and remove all the parts which can be taken out from the machine. This means – juice bath (**1.19 Fig.**), washing bath (**1.20 Fig.**), juice draining plates (**1.21 Fig./1.22 Fig.**), inlet head (**1.23 Fig./1.24 Fig.**). Just leave the cover and scrappers (**1.10 Fig./1.11 Fig./1.12 Fig.**) on machine.
- Remove all the leftover of fruit mass manually or by water stream.
- Turn on the machine and belt washing again and start to wash the shafts from biggest one to the smallest one by removing the fruit mass by water stream. Continue this process until no fruit mass is left and belt press is clean.
- Then put the pneumatic cover up (**1/1.10 Fig.**) with the buttom on the left on electric cabinet (For powerpress 400 just remove the whole cover manually (**1.8 Fig./1.9 Fig.**)). Finish washing without the cover and scrappers.
- All the removed parts wash manually by water stream.
- After washing is done put all the parts back into the place.

✓ **Removing the juice bath:**



1.17 Fig.

1. Disconnect the pump hose from the juice bath.



1.18 Fig.

2. Disconnect the juice bath level sensors.



1.19 Fig.

3. Remove the juice bath from the press

✓ **Removal of the washing bath:**



1.20 Fig.

1. Remove the juice washing bath from the press

✓ **Removing juice draining plates:**

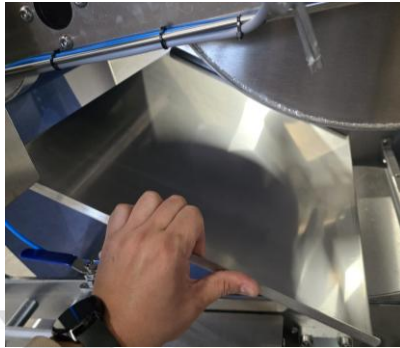

1.21 Fig.

2. Remove left the juice draining plate

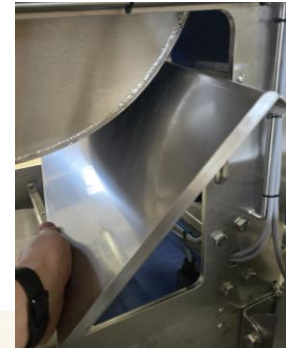

1.22 Fig.

3. Remove right the juice draining plate

✓ **Removing the inlet head**



1.23 Fig.

1. Unfasten the 4 holders on both sides



1.24 Fig.

2. Removed the inlet head

The pressing process

- The fruit, berry or vegetable mash is loaded into the press through the loading hopper.
- The mash falls onto the belt and is pneumatically pressed by the cylinders. The pressing process is continuous, the mash is pressed between the belt and cylinders.
- When the mash comes through all the cylinders, it comes out through pressed mash leftover tray and usually is transported by the screw conveyor.

- The pressed juice flows into juice collection tank. If juice is not being extracted from the juice bath, check the direction of rotation of the pump. To change the direction of rotation of the pump, swap the power phases. Swap the wires of contacts 1 and 2 in row X1. To remove the cable, press the orange part (1/1.25 Fig.).
- The pneumatic belt system always keeps the belt centered. The press belt is controlled by a pneumatic valve (1/1.27 Fig.).
- The belt press works continuously as long as there is enough mash to press.

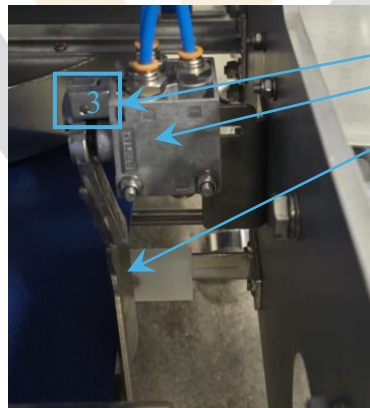
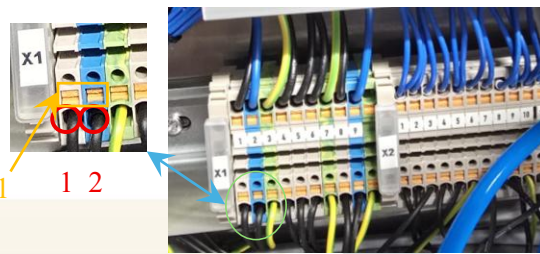

1. Pneumatic valve that controls the belt adjustment cylinder (1.26 Fig.).
2. Pneumatic valve pad that touches the belt (2/1.27 Fig.).

✓ If the cylinder starts to slip with a twitch (1.26 Fig.), the connection (3/1.27 Fig.) must be loosened and lubricated.

- ✓ If the press belt has shifted to one side or the other and there is an active error **Belt Position Fault (5/1.11 Fig.)** one of the sensors will be activated 1 or 2 (**Fig. 1.28.**).

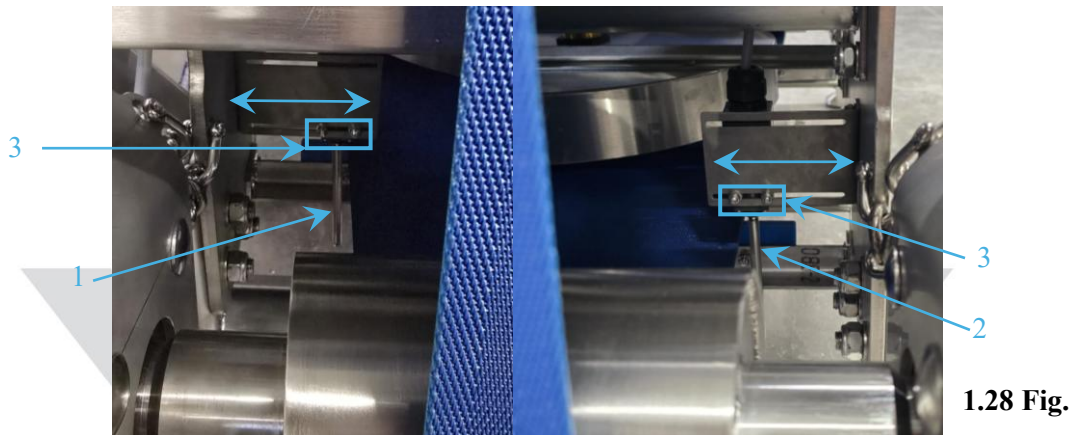

When the press stops due to one of the safety sensors being triggered, the belt must be manually adjusted to the center. If the press stops unexpectedly and the air does not escape from the pillow and the belt cannot be adjusted by hand. Loosen the two M4 screws (**3/1.28 Fig.**) and push the sensor away so that the press can start and the excess crushed mass can be removed from the press. Then the press belt is placed in the center and the sensor must be returned to its original position and the M4 screws tightened. For the center of the belt, see the page 22.

Conditions for using the machine

- The machine, its workplace and ground must be kept clean, neat and properly lit at all times when using it.
- A higher than 1,8 m room or using area is required.
- The area around the machine needs to be empty so machine would not be bothered with any interference.
- The machine is operated by one person who has passed his training with the machine and is familiar with all the instructions and risks.

- Flat, stable and solid ground is needed for machine, the ground must hold 700 kg weight. This stable ground is always obligatory: when using the machine, during transportation, assembly, dismantling, testing, foreseeable failure or non-usage periods.
- When transporting, lifting or storing the machinery the client is obligated to assure its safety and proper fastening.
- When using the machine for the first time after a long period of not using it, the cylinders need to be lubricated. Bearings must be lubricated every 40-50 tons of product. After washing with a high-pressure washing device, check that no water has entered the bearings. If water has entered, lubrication must be performed after washing.

Press level adjustment

Step 1: Level the front of the Powerpress with a spirit level. Place the spirit level on the shaft.

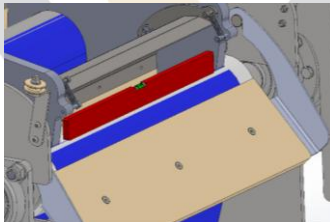

Step 2: Loosen the locknut. Adjust the Powerpress straight using a spirit level, lengthening or shortening the adjustable leg.

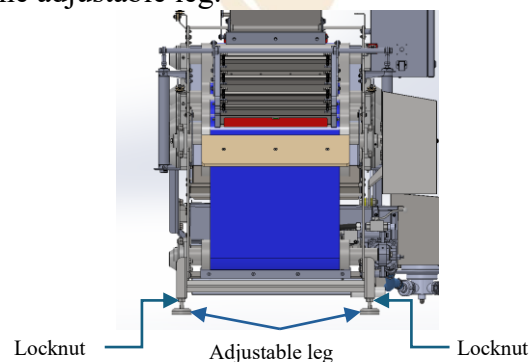

Step 3: Level the end of the Powerpress with a spirit level. Place the spirit level on the shaft.

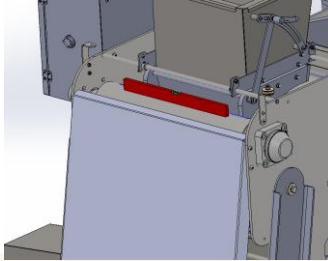

Step 4: Loosen the locknut. Adjust the Powerpress straight using a spirit level, lengthening or shortening the adjustable leg.

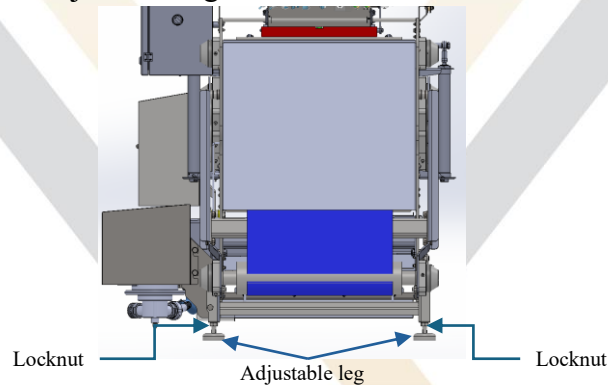

Position the press belt in the center. The distance from the inside of the press side plate to the belt should be 84 mm.

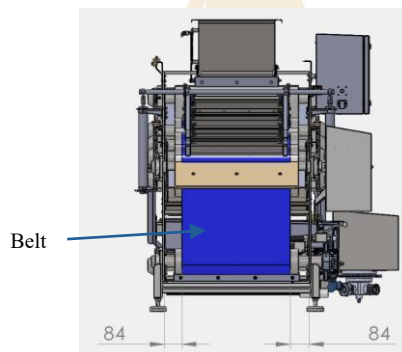

If the belt moves to one side or the other when the press is started, you need to loosen the M6 screws that hold the pneumatic valve.

If the belt moves to the right, you need to push the pneumatic valve in the same direction. If the belt moves to the left, you need to push the pneumatic valve to the left side as well.

Every time you try to make sure the belt moves straight, tighten the M6 screws. **(This step is only performed if Powerpress alignment with a spirit level has not helped.)**

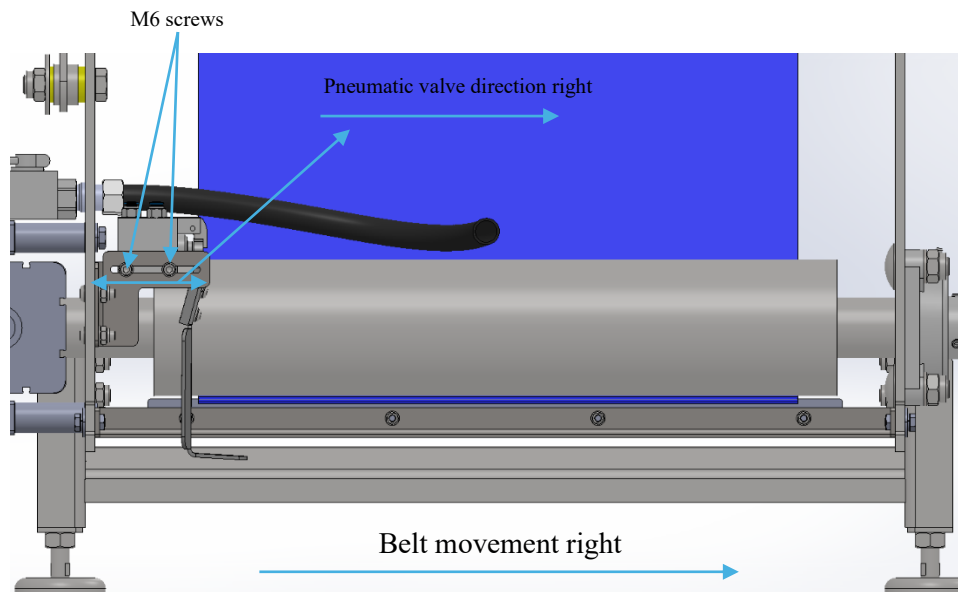

Safety requirements

- If some machinery failure, obstacle, accident, emergency or any other dangerous situation happens it is obligatory to stop, shut down the machinery immediately or operate equipment depending on the situation in order to avoid or eliminate dangers.
- The machinery can be operated only by person who has passed his training for machinery and is familiar with all the machinery instructions and risks. The person must also be in proper physical and mental state and not be affected by any substances that could interfere with normal functioning (such as pharmaceuticals, drugs, alcohol etc.).
- It is prohibited to do any activity with the machine during its working process (such as washing, transporting etc.).

- It is prohibited to wet or pour any liquids onto the central control box and engines.
- Every time before using the machine the operator must carefully inspect the machine, check if all the parts and electrical buttons are in place and working properly as well as examine if the equipment meets all the safety requirements and is prepared for normal work.
- The central control box and engines can be fixed, repaired or changed only by the manufacturer or by approval. All the engineering and electrical works must also be performed by the manufacturer or by approval.

Warnings

- It is prohibited to put products or things into the machine that could damage or cause any harm to it. Only products that can be identified as fruit, berry or vegetable mash can be used with this machine.
- It is prohibited to put unprocessed and not properly prepared fruits, berries and vegetables into the press (such as not crushed products, products containing stones, leaves, big chunks of products etc.). It is prohibited to put any products that could clog, stop or improperly aggravate the work or harm the machine and its parts in any way (such as tomatoes, watermelons, peaches, etc.).
- The belt press only presses fruit, berry and vegetable mash that is processed and has no stones, leaves, branches or other obstacles that could harm the machine. Only products that are mashed or cut into small pieces can be used. When using ordinary berries suitable for pressing, additional safety actions are not required (such as grapes, raspberries, etc.).
- When pressing other products than apples, the efficiency of the machine can differ and additional actions for smoother work process may be required (such as using a slower pressing mode, paying more attention to cleaning the cylinders, etc.).
- It is forbidden for any people to touch, lean on or have contact in any way with the working machine, its parts, the products that are being processed or other dangerous parts

because of the risk of injury. Only actions that are necessary for a proper work with the machine are allowed.

- All machinery parts, buttons and operational details must be used according to their purpose.
- Any arbitrary adjustment, repair or other mechanical modification of the machine by a non-manufacturer will result in termination of the warranty service.
- It is prohibited to climb or put things on the machine at all times.
- The machine can only be washed, lifted, transported or otherwise operated after it was switched off completely.
- The cover of the central control panel is opened with a special key by an operator or warranty service person.
- The machine only works properly when all its parts are properly attached.
- Maintenance of the machine (such as lubrication of machine bearings, etc.) must only be carried out by manufacturer or its approved company.
- The manufacturer produces and prepares the machine based on all machinery requirements and client's needs. Changing and mechanically adjusting any machinery settings without manufacturer or its approval is prohibited.
- If a machine failure, defect or other malfunction is noticed, contact the manufacturer for troubleshooting, warranty service or other solution within 5 working days.

Residual risks

- The risk of sound and vibration (depending on workload), water splashes and the possibility of getting wet still remains even in compliance with all safety requirements.

Precautionary directions

- Before using the machine, the operator must inspect the machine for defects and meet all safety requirements. If discrepancies are found, do not use the machine until they have been eliminated.
- It is recommended to remain attentive around the machine and to keep a distance from the machine and its pressing parts when it is not necessary.
- If the situation requires contact with parts of machinery that are hazardous to health or dangerous to environment, additional precautions must be taken: consultation with the manufacturer, usage of other equipment or tools, wearing protective gloves and other actions depending on the situation.
- It is recommended to wear clothing and footwear that is non-slip, water resistant and is appropriate for work.
- It is recommended to follow all additional safety requirements in order to stay safe and prevent any injuries.

Transportation of machine

- The machine is transported by truck.
- The machine is transported in one piece without separating its parts.
- During transportation the machine must be secured in such a way that its components are not damaged and the machine itself remains stable during transport.
- When transporting and otherwise moving or changing the position of the machine it must be done after it had been completely switched off, emptied and securely fastened.
- The machine has to be put straight during transportation.

Machine operation in case of risk

- In the event of accident or emergency operate the machine depending on the situation: stop, shut it down, return to a safe or less dangerous position immediately and eliminate the danger.

- If the machine breaks down, switch off the machine and evaluate the failure. If the failure cannot be eliminated by yourself (such as removing the dirt, other obstacles) or it is dangerous, contact the manufacturer for warranty service, if the warranty service has expired, apply for repair.
- In case of jammed machine assess the situation, inspect the jammed part of the machine and try to solve it if there is no danger. Depending on the situation try restarting the machine or contacting the manufacturer for warranty service or repair.

Adjustment and maintenance of machine

- Inspect machine parts (pressing parts, belt, cylinders, pump, juice collection tray, etc.) before every use, regularly check machinery.
- Wash the machine regularly (after each shift).
- Wash the filter sieve approx. every 3 hours (depending on the workload).

Troubleshooting

Troubleshooting must only be carried out by an authorized and qualified person, with the right and appropriate skills and training for the job.

Disturbances / error	Possible reason(s)	Remedy
Machine does not function	Phase missing Phase swapped	Have an electrician to check this or change the phases
Machine does not function	EMERGENCY STOP pressed	Unlock EMERGENCY STOP
Machine not starting	The PROTECTIVE WIRE is triggered	Pull the Protective wire switch, if needed tighten the red cable in the back. Press RESET.
The machine stops working and the MOTOR FAULT indicator lights	Motor thermal relay error	Check and reset motor thermal relay. Have an electrician to check this.
The belt is not properly tightened, AIR PRESSURE FAULT ACTIVATED	Lack of air supply	Check that the air compressor is connected correctly.
BELT POSITIONING ERROR ACTIVATED	The belt moved out of it's place	Disconnect the air supply and center the belt into positions manually. In the bottom there is two sensors for belt positioning, check if sensors are not damaged. Press RESET and continue the work.