

ProFruit Machinery™ is a family-based company that started with a father and son and their shared desire to offer more fruit, berry and vegetable processing possibilities for both leaders of their market and businesses that aspire to become such one day.

For almost 10 years we have been working with various fruit, berry and vegetable processing equipment in our juice production-based company “Savos sultys”. This way we have tried and tested the equipment from almost all producers in the market including it’s leaders. We have gained an extensive experience working with all the equipment parts of the processing lines, we constantly communicate with other producers and users of this equipment and for these reasons we truly understand what the effective work in fruit, berry and vegetable processing field requires.

Our core values are reliability, the highest quality and comprehensive assistance to the client in all matters. These values are also supported by the fact that our team consists of true professionals who have been working in a food processing equipment industry for more than 20 years and are capable of ensuring all the best engineering solutions.

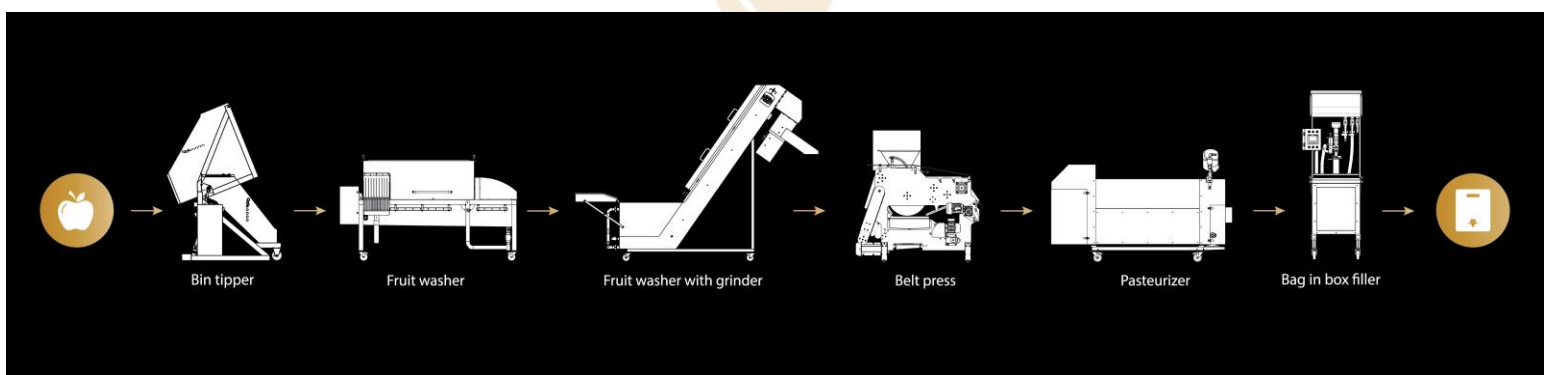

COMMERCIAL OFFER FOR A VEGETABLE LINE.
THIS LINE OFFER IS JUST REPRESENTATIONAL,
CONTACT US AND WE WILL PREPARE YOU THE
EXACT LINE OFFER ACCORDING TO YOUR NEEDS

CAPACITY 1200 kg/h

Description	Quantity	Capacity	Price EUR.	Pack. Cost Eur
Bin Tipper UNLOADER 800	1	800kg loading power	6 490.00	160.00
Sorting conveyor 3000x400	1		4 080.00	80.00
Fruit and vegetable washer elevator mill AQUAMILL 3000 with bubble washing	1	3000 kg/h	14 500.00	160.00
Belt press POWERPRESS 1200 (high pressure washer, integrated pump and juice collection tank are included)	1	1200 kg/h	31 500.00	160.00
Screw conveyor for pressed fruit mash, 4 m.	1	3000 kg/h	5 150.00	80.00
Stainless steel Closed type tank with oval manhole on top, CIP washing ball, conical bottom, 1000l	1	1000 l	2 500.00	80.00
Mixer for stainless steel tanks with DN50 connection	1		2 350.00	80.00
6 heads manual bottle filler GRAVITY with liquid level sensors, no return valve, product thermometer	1	900 l/h	2 200.00	80.00
Capping machine for Aluminium screw caps (MCA)	1	Up to 500bot/h	6 600.00	80.00
Semi-automatic tabletop bottle labeller	1	Up to 800bot/h	3 400.00	80.00
START UP SET FOR WHOLE LINE (air compressor, hoses, connections, fittings.)	1		1 500.00	
TOTAL:			81 310.00	

1. Ex-works Lithuania.
2. Production time: 20-26 weeks.
3. Country of origin: EU.
4. Made from stainless steel materials.
5. Complies with EU standard CE certificates.
6. Payment terms – 50% with the order, 50% before loading the equipment.
7. Equipment is covered by 36-month warranty. Warranty period for bearings, engines and other bought parts are 12 months.

UNLOADER 800 is a first processing step during which the machine transfers fruit, vegetable or berries to the next stages of processing: washing, sorting or crushing. Bin tipper lifts the box and pours out the products into sorting conveyor, AQUA or MAXIMILL.



- Bin tipper is entirely made of stainless steel.
- The machine has a hydraulic drive.
- The control of the machine are very simple: just put the box in and move the control handle to lift it up.
- Suitable for boxes with different dimensions. Max size: 120x120x85.
- Loading power – 800 kg.

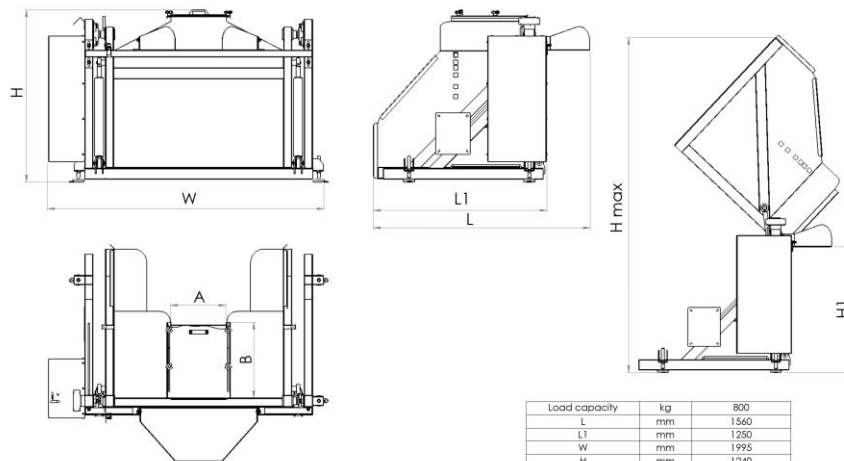

	Machine	BIN TIPPER
	Type	UNLOADER 800

Load capacity	kg	800
L	mm	1560
L1	mm	1250
W	mm	1995
H	mm	1240
H1	mm	965
H max	mm	2570
AxB	mm	400x540
Box max size W x L x H	mm	1200x1200x850
Dry weight	kg	330
Supply source	kW	1.6
Supply voltage	V	3/N/PE - 400 V 50Hz

Sorting conveyor is used in a fruit, berry and vegetable processing line for sorting and drying the products.

Sorting conveyor transports products from one machine to the other. We produce two different length sorting conveyors: 1,5 m and 3 m length. We also accept individual orders for machine with different measurements.



- Measurements: 1500×400 and 3000×400 mm.
- Simple and user-friendly maintenance.
- Convenient sorting tape non-conditional fruits and vegetables.
- Machine also has pivoting wheels.
- Sorting conveyors are easy to clean after using

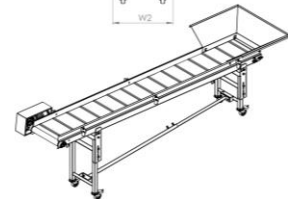
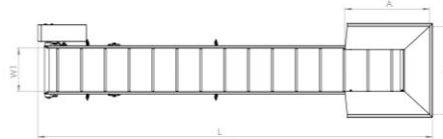
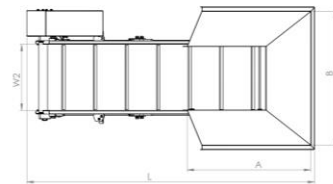
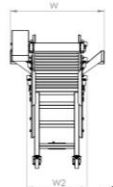
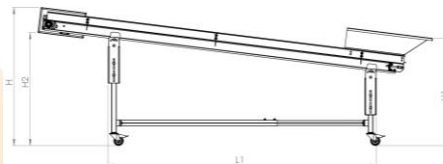
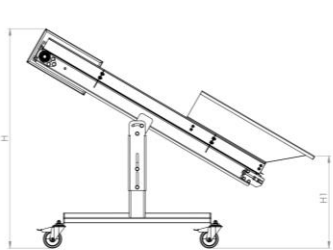

	Machine	Sorting conveyor for sorting and drying the products
	Type	SC - 1500

W	mm	780
H	mm	1120 - 1200
H1	mm	500 - 420
L	mm	1580
W1	mm	480
W2	mm	360
AxB	mm	680x730
Weight	kg	75
Supply source	KW	0.37
Supply voltage	V	3/N/PE - 400 V 50Hz

	Machine	Sorting conveyor for sorting and drying the products
	Type	SC - 3000

W	mm	780
H	mm	1120 - 1200
H1	mm	840 - 930
H2	mm	895 - 975
L	mm	3280
L1	mm	2230
W1	mm	340
W2	mm	500
AxB	mm	704x730
Weight	kg	180
Supply source	KW	0.37
Supply voltage	V	3/N/PE - 400 V 50Hz

The fruit bubble washer elevator mill **AQUAMILL** is made from stainless steel. Machine is suitable for various fruits, berries and vegetables.

Firstly, the operator of the machine pours products into the bubble washing tub with clean water. The tub is connected to the air flow which leads to water circulation and creates a bubble washing effect on products. The bubble washing provides excellent cleaning as well as helps fruits, berries and vegetables move straight to the elevator, granting a more convenient work process. Then conveyor lifts the products up to the mill which crushes them into a mash. During the lifting process, water nozzles spray fruits, berries and vegetables with clean water. The product mash falls out of the mill for further pressing or destoning process.



- Machine has a bubble washing tub which provides excellent cleaning as well as helps fruits, berries and vegetables move straight to the elevator.
- The bubble washing tub is spacious and can contain big amount of products at once.
- The crushing head of the machine is round, so all the crushed mash goes directly out for further processing. This feature significantly helps when washing the head as there are no corners. Our round shape technology is superior to other producers', because a lot of fruit mash gets stuck in the corners of square-shaped heads for hours and can cause juice fermentation!
- Fruit bubble washer elevator mill has additional table in front of the basin for putting fruits or boxes on it.
- Integrated water-spraying system provides additional



- washing when lifting the fruits up the conveyor.
- Belt conveyor has a water drainage and speed regulation system.
- Optional replaceable cutting graters/sieves are available for different fruits and berries.
- The mill does not damage the fruit seed.
- Powerful 5.5 kW crushing engine can crush various fruits, berries and vegetables – from soft raspberries to hard apples, beets, etc.
- Machine is entirely made of stainless steel and easy to clean after using.

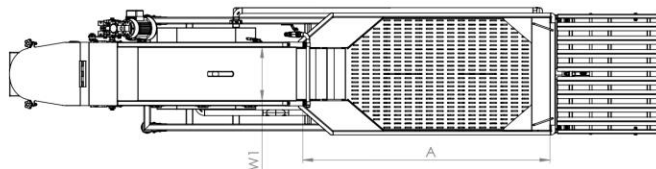
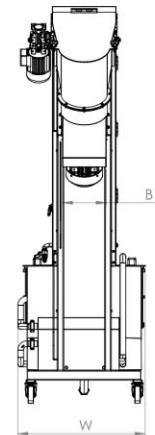
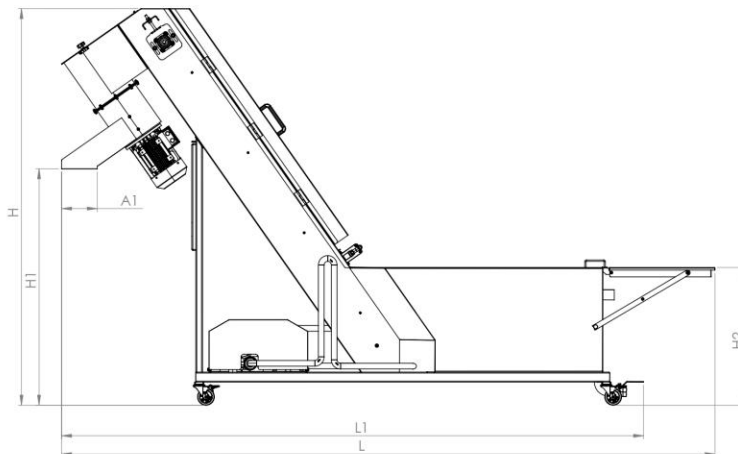

Output	kg/h	3000
L	mm	3860
L1	mm	3437
W	mm	760
W1	mm	320
H	mm	2342
H1	mm	1396
H2	mm	813
AxB	mm	1460x668
A1xB1	mm	210x258
Dry weight	kg	225
Supply source	kW	6.8
Supply voltage	V	3/N/PE ~ 400 V 50Hz

	Machine	Fruit and vegetable washer-elevator-grinder
	Type	AQUAMILL 3000

Belt press **POWERPRESS 1200** is designed for pressing fruit, berry and vegetable mass. Fruit mass is placed on the belt which presses it against cylinders.

The obtained juice flows into integrated collection tank under the press. Then the pump transfers the juice from the press to a desired tank for further processing. The pressing process is continuous.

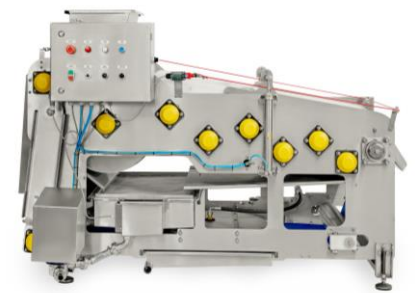

- The most evolutionary feature of our Belt press POWERPRESS line is that belt presses come with integrated pump and juice collection tank. This means you save money and do not need an additional juice collection tank and pump which otherwise would use much space and cause additional costs.
- The juice yield of apples using our belt press is ~75 %.
- There is a filtration sieve integrated into the juice collection tank. Because of that the belt press 1200 filtrates the juice even during the pressing stage providing cleaner and purer product.
- The belt presses work automatically: when the mash inlet tank is full, all other machines, which come before belt press, turn off automatically. When the juice tank is full, the pump automatically pumps the juice into the tanks.
- The belt press includes a high-pressure washer, which continuously washes the belt of the machine. Our belt washing system is simple, does not contain any engines or reducers, so it prolongs the use time and saves service costs.



- After work, belt press should be manually washed with a water stream. A full washing process takes around 15-20 minutes. Washing is simple and all the parts of the belt press are easily removable without any tools.
- Pneumatic lifting of the security cover of the press ensures easier access when cleaning.
- Belt tension is adjustable.
- The machine is made entirely of stainless steel and has adjustable feet.
- Easy to clean with no closed or inaccessible spaces, all parts are easy to assemble
- Different efficiency [POWERPRESS 400](#), [POWERPRESS 800](#), [POWERPRESS 1500](#)

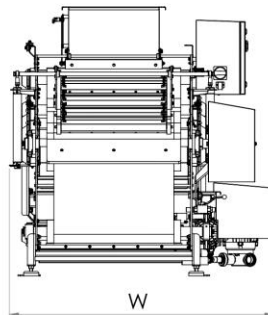
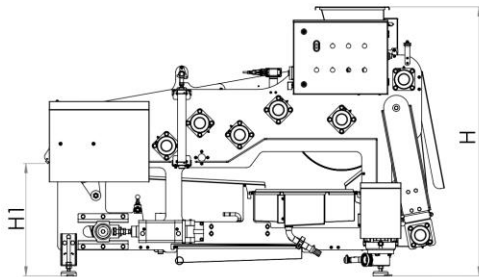

Output	kg/h	1200
L	mm	1995
W	mm	1325
H	mm	1350
H1	mm	570
T	mm	600
AxB	mm	315x450
Weight	kg	720
Supply source	kW	1.1
Supply voltage	V	3/N/PE ~ 400 V 50Hz

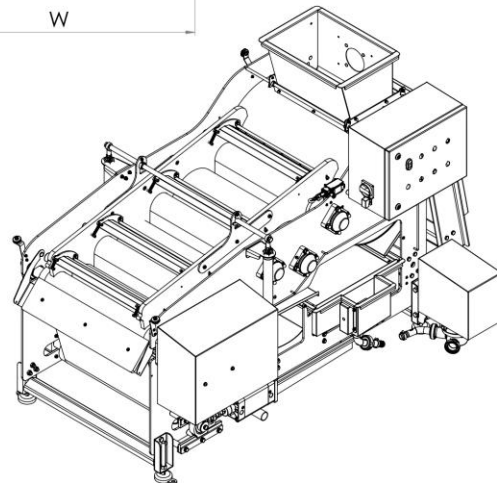
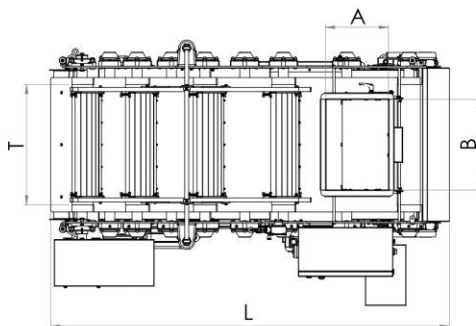

	Machine	Belt press
	Type	POWERPRESS 1200

Screw conveyor is used to transport a leftover mash from press.

The leftover fruit, berry or vegetable mash enters the loading hopper of the screw conveyor.

The screw inside the machine is continuously turning and this way transports the mash from the loading hopper to the exit outlet at the top of the machine. The mash exits the machine.

- Screw conveyor is made of stainless steel.
- Machine has a closed tunnel.
- Conveniently transports leftover pressed mash from press.



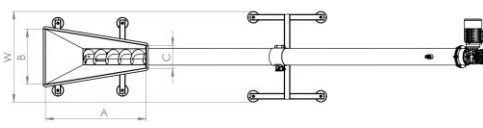
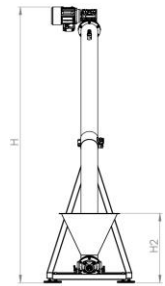
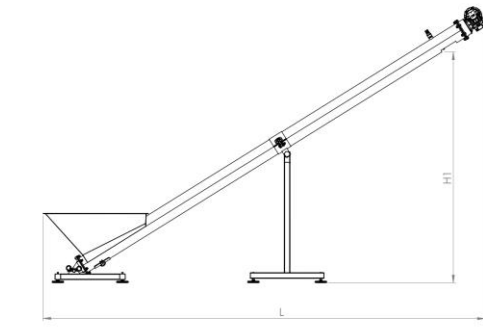
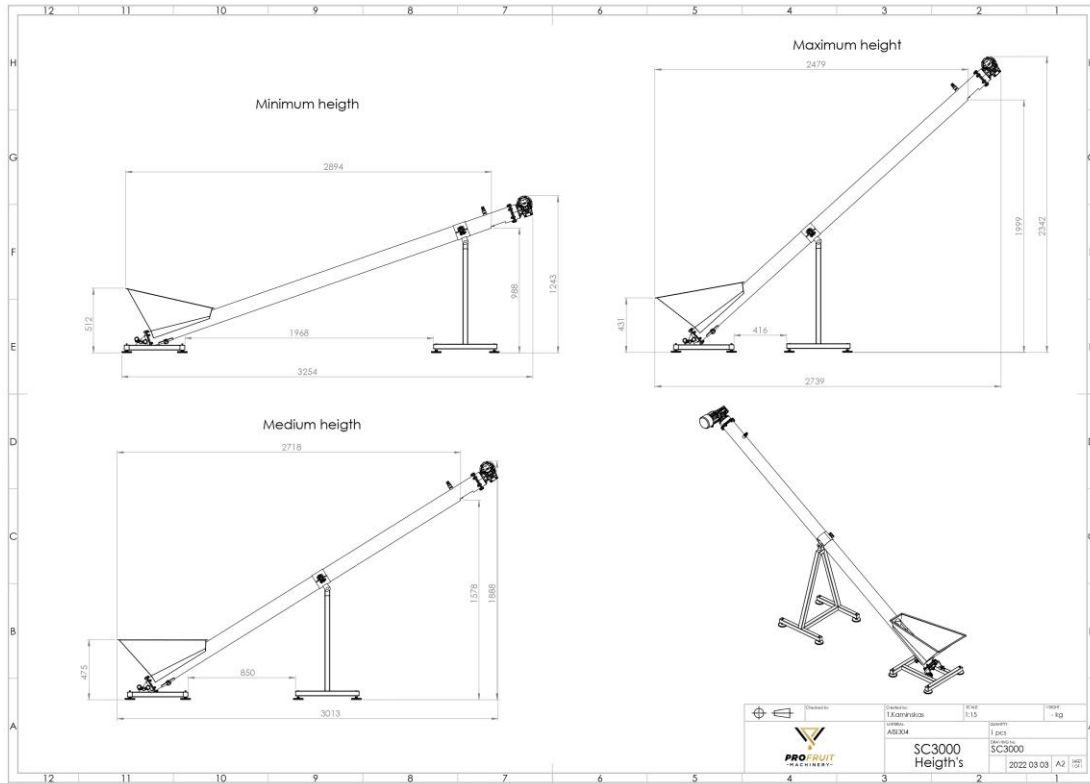

Type	SC3	SC4	SC4.5
L, mm	3013	3945	4358
H, mm	1891	2461	2725
W, mm	620	620	620
Output, kg/h	1700	1700	1700
H2, mm	440	440	440
AxBxC, mm	685x377x156	685x377x156	685x377x156
Supply source, kW	0.4	0.4	0.4
Supply voltage, V	3/N/PE - 400 V 50Hz	3/N/PE - 400 V 50Hz	3/N/PE - 400 V 50Hz

	Machine	Screw Conveyor for Pressed Mash
	Type	SC3000, SC4000, SC4500

JSC/UAB PROFRUIT MACHINERY
www.pro-fruit.com
info@pro-fruit.com
 Ph. Nr. +370 633 64143

Closed type tank 1000 L:

- Diameter of the tank 955 mm
- Hight of the jacket 1500 mm
- Hight legs 400 mm 3 pcs
- Adjustable legs 3 pcs
- Material AISI304
- Bellow and on the top dish bottom
- Cooling jakcte hight 750 mm (max working pressure 1,8 bar)
- On the site oval manhole art. A5 Fratelli Laveggi
- Total outlet inox butterfly valve DN40
- Parcial outlet inox butterfly valve DN40
- Carbonation stone DN40 with inox ball valve BSP3/8«
- Digital termometer with inox probe BSP1/2«
- Inox sample tap DN20
- On the back site inox probe BSP1/2«
- Inox table with technical data
- Inox support for ladder
- On the to safety valve BSP1/2«
- On the top inside CIP rotation spray ball, outside inox tube with inox butterfly valve DN40on
hight 1200 mm
- Pressure regulator art. Vario fixed on the CIP tube
- Max working pressure into tank 2 bar
- All internal welds are flat and high polish
- External surface are marbelated

Tank with agitator is the perfect choice for containing and mixing various liquid products (including viscous products), such as different juice, puree, sauce, broth, etc. Tank with agitator is a great choice especially for mixing various juices, e.g. apple, carrot, berry, etc.



Mixer's connection fitting (garolla DIN 11851, TRICLOVER, etc.) and mechanical seal (standard steel/graphite) can be made by a customer request according to necessary specifications. All machine's parts in contact to the product are made from stainless steel AISI 304.



- Power: 0.75 kW
- Rod length: 650 mm
- Speed 1400 RPM
- Propeller width: 155 mm
- Weight 20 kg
- Maximum tank capacity: 200 hl
- Comes with anti-dust cover which protects the liquid inside.
- Stainless steel tanks are easy to clean after using.

Manual bottle filler **GRAVITY** with 6 filling heads fills various liquids into the bottles.

The manual bottle filler is especially easy to use. The filling mechanism works based on gravity. The handle is pulled down and the strong stream of liquid flows out of the head.



- Capacity – 600 pcs. of 0,5 L bottles per hour.
- The bottle filler is completely made of stainless steel.
- Gravitational mechanism provides a strong stream as well as easy and effective work.
- Comes with a buffer tank for fluid.
- Buffer tank has an integrated flowmeter which helps to follow the liquid level on the buffer tank.
- Suitable for various liquids that are similar to water consistency such as juice, wine, vodka, etc.
- Mounted on the pivoting wheels.



Capping machine for Aluminium screw caps (MCA) is a simple and easy to use machine for capping various size aluminium screw caps. Operator places the bottle on the table, puts the cap onto the bottle and press two buttons on the side to start the process.

Capacity: up to 600 pcs. bottles per hour.

Capper for aluminium screw caps is a simple and easy to use machine for capping various size aluminium screw caps. Operator places the bottle on the table, puts the cap onto the bottle and press two buttons on the side to start the process.



- Whole capping and threading process takes 2.5 seconds.
- AISI 304 stainless steel frame.
- It shapes smooth capsules on the threaded neck of the bottles and makes the lower rim.
- Capsules: 31,5 mm diameter and 24 mm height (standard version). But it is possible to change these settings and make this machine suitable for capsules with other dimensions.
- Diameter of the bottles: up to 195 mm.
- Maximum height of the bottles: 340 mm.
- Manual loading of the capsules.
- Capping time: about 2,5 seconds.
- 230 V, 50 hz, one phase el. supply.

Semi-automatic tabletop single station labelling

machine. The front and back self-adhesive labels can be labelled in the same cycle using one bobbin with alternating front and back body label, for cylindrical bottles, glass jars, and other containers. Productivity 800 Bt./h.



Semi-automatic tabletop single station labelling machine. The front and back self-adhesive labels can be labelled in the same cycle using one bobbin with alternating front and back body label, for cylindrical bottles, glass jars, and other containers. Complete with a LED digital electronic control panel to perfectly centre the labels.

On request the machine can be supplied with INK STAMPING UNIT driven by a pneumatic mechanical arm or INK JET PRINTER for printing date of production or expiration date.



- Made from Stainless Steel.
- Single reel front and back label single passage.
- Led photo detector for reel passage and bottle presence.
- Digital control panel for maximal precision.
- Max. reel height 140 mm. On request.
- For round bottles in 60-120 mm diameter as standard. 35-60 mm or 120-200 mm diameter on request.
- Can be used with square bottles on request
- Power supply: Kw. 0,20 230 v. 50 Hz.
- Plenty of different options on request.
- Productivity 800 Bt./h.