

ProFruit Machinery™ is a family-based company that started with a father and son and their shared desire to offer more fruit, berry and vegetable processing possibilities for both leaders of their market and businesses that aspire to become such one day.

For almost 10 years we have been working with various fruit, berry and vegetable processing equipment in our juice production-based company “Savos sultys”. This way we have tried and tested the equipment from almost all producers in the market including it’s leaders. We have gained an extensive experience working with all the equipment parts of the processing lines, we constantly communicate with other producers and users of this equipment and for these reasons we truly understand what the effective work in fruit, berry and vegetable processing field requires.

Our core values are reliability, the highest quality and comprehensive assistance to the client in all matters. These values are also supported by the fact that our team consists of true professionals who have been working in a food processing equipment industry for more than 20 years and are capable of ensuring all the best engineering solutions.



**COMMERCIAL OFFER FOR A FULL JUICE  
PRODUCTION LINE  
CAPACITY 400 KG/H**

Description	Quantity	Capacity	Price EUR.	Pack. Cost Eur
Bin Tipper <b>UNLOADER 500</b>	1	500 kg lifting power	6 490.00	160.00
Sorting conveyor <b>1500x400</b>	1		2 980.00	80.00
Fruit and vegetable washer <b>AQUA 3000</b>	1	3000 kg/h	6 590.00	160.00
Fruit and vegetable washer elevator mill <b>MAXIMILL 1000</b>	1	1000 kg/h	6 990.00	160.00
Belt press <b>POWERPRESS 400</b> (high pressure washer, integrated pump and juice collection tank are included)	1	400 kg/h	14 500.00	80.00
Screw conveyor for pressed fruit mash, 3 m.	1	3000 kg/h	4 400.00	80.00
Stainless steel mechanical juice filters (0,25 mm filter element)	1	2000 l/h	1 990.00	50.00
Stainless steel open tanks with anti-dust cover	1		optional	
Diesel pasteurizer <b>HEAT 500 (53kw)</b>	1	500 l/h	10 900.00	80.00
Semi-automatic Bag in Box and Stand-up Pouch filler <b>SEMIFLOW</b> (with buffer tank – option without a buffer tank costs less)	1	1000 l/h	7 600.00	80.00
Central electrical cabinet with connections between machines (bin tipper – conveyor – washer – elevator – mill – belt press)	1		2 680.00	80.00
Start-up Set	1		1 500.00	
<b>TOTAL:</b>			<b>67 630.00</b>	

1. Ex-works Lithuania.
2. Production time: 8-10 weeks.
3. Country of origin: EU.
4. Made from stainless steel materials.
5. Complies with EU standard CE certificates.
6. Payment terms – 50% with the order, 50% before loading the equipment.
7. Equipment is covered by 36-month warranty. Warranty period for bearings, engines and other bought parts are 12 months.

**UNLOADER 500** is a first processing step during which the machine transfers fruit, vegetable or berries to the next stages of processing: washing, sorting or crushing. Bin tipper lifts the box and pours out the products into sorting conveyor, [AQUA](#) or [MAXIMILL](#).



- Bin tipper is entirely made of stainless steel.
- The machine has a hydraulic drive.
- The control of the machine are very simple: just put the box in and move the control handle to lift it up.
- Suitable for boxes with different dimensions: 120x80x100, 100x100x120, 120x100x100 and similar.
- Loading power – 500 kg.

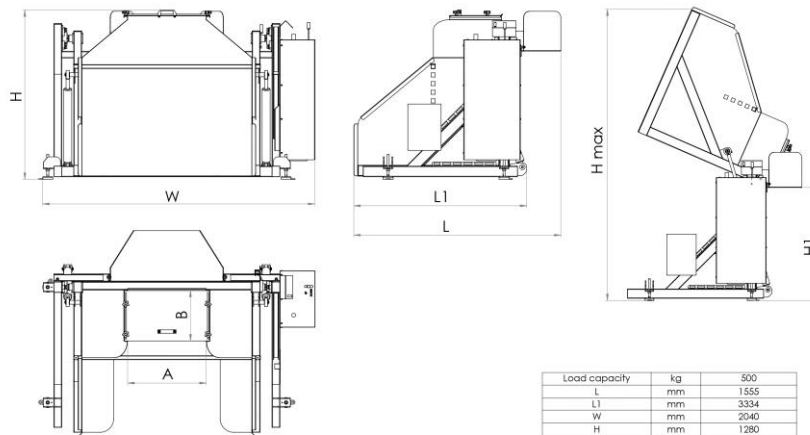

	Machine	BIN TIPPER
	Type	UNLOADER 500

Load capacity	kg	500
L	mm	1555
L1	mm	3334
W	mm	2040
H	mm	1280
H1	mm	965
H max	mm	2505
AxB	mm	588x380
Box max size W x L x H	mm	1250x1100x800
Dry weight	kg	330
Supply source	kW	1,6
Supply voltage	V	3/N/PE – 400 V 50Hz

**Sorting conveyor** is used in a fruit, berry and vegetable processing line for sorting and drying the products.

Sorting conveyor transports products from one machine to the other. We produce two different length sorting conveyors: 1,5 m and 3 m length. We also accept individual orders for machine with different measurements.



- Measurements: 1500×400 and 3000×400 mm.
- Simple and user-friendly maintenance.
- Convenient sorting tape non-conditional fruits and vegetables.
- Machine also has pivoting wheels.
- Sorting conveyors are easy to clean after using

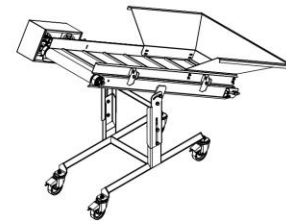
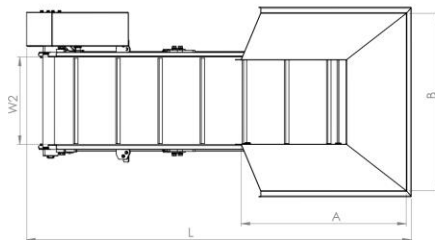
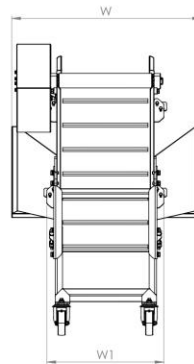
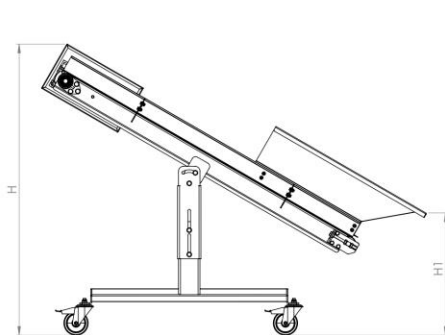

	Machine	Sorting conveyor for sorting and drying the products
	Type	SC - 1500

W	mm	780
H	mm	1120 - 1200
H1	mm	500 - 420
L	mm	1580
W1	mm	480
W2	mm	360
AxB	mm	680x730
Weight	kg	75
Supply source	kW	0.37
Supply voltage	V	3/N/PE - 400 V 50Hz

**Fruit and vegetable washer AQUA 3000** is designed for washing and cleaning fruits and vegetables before processing. Fresh water and soft brushes leave the product intact, wash gently and cleanly.



- Fruit washer is entirely made of stainless steel.
- The washer is easy to clean after use.
- The washer cover can be opened for inspection and cleaning.
- Central command box provides operation of the machine.
- The speed of the washer is adjustable – the speed of the washer dictates the capacity of the processing line.
- Fruit washer has pivoting wheels.
- There is a gradual exchange of water during the washing: the inflow of fresh water comes in at the exit of the washer, the outflow of the wastewater goes out through the small tube at the entrance of the washer.
- A long slide at the outlet of the provides better draining process of fruits and removal of dirt (e.g. leaves, branches, etc.).

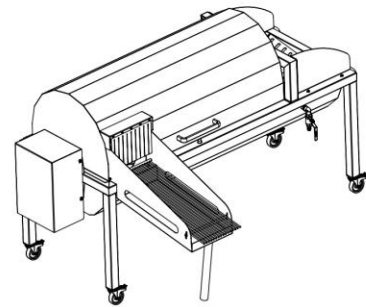
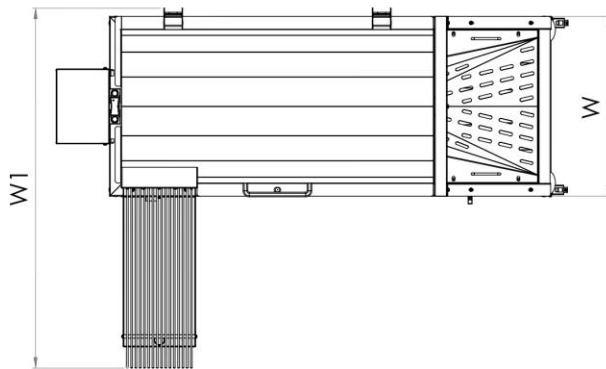
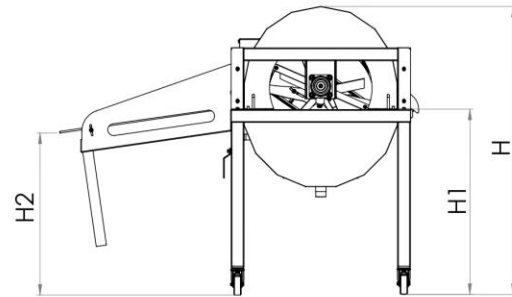
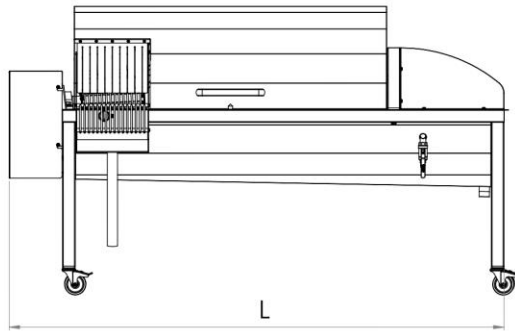

	Machine	Fruit and vegetable washer
	Type	AQUA-3000

Output	kg/h	3000
L	mm	2320
W	mm	840
W1	mm	1682
H	mm	1345
H1	mm	865
H2	mm	725-780
Weight	kg	270
Supply source	kW	0.8
Supply voltage	V	3/N/PE ~ 400 V 50Hz



The fruit washer **MAXIMILL1000** is made from stainless steel. Firstly, the operator of machine pours fruits and vegetables into the washing tub with clean water. Conveyor lifts the products up to the mill. During the lifting process, water nozzles spray the fruits and vegetables with clean water. The mill crushes the products after they reach the top of the conveyor. Finally, the fruit and vegetable mash come out of mill.





- The crushing head of the machine is round. All the crushed mash goes directly out for further processing. This feature significantly helps when washing the head, as there are no corners. Usually a lot of fruit mash gets stuck in the corners of square-shaped heads for hours and can cause juice fermentation. For that reason, our round shape technology is superior to other producers'.
- The machine has an additional table in front of the basin for putting fruits or boxes on it. It facilitates the process of pouring the products into the basin.
- V form washing basin helps fruits and vegetables move directly to the conveyor, therefore less fruit stay in the basin.
- Integrated water-spraying system provides additional washing when lifting the fruits up the conveyor.
- Belt conveyor has a water drainage and speed regulation system.
- The speed of the belt conveyor is adjustable in the

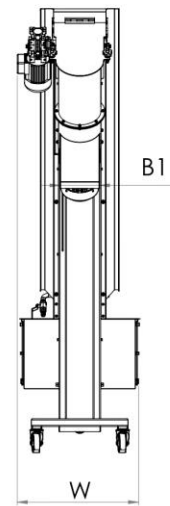
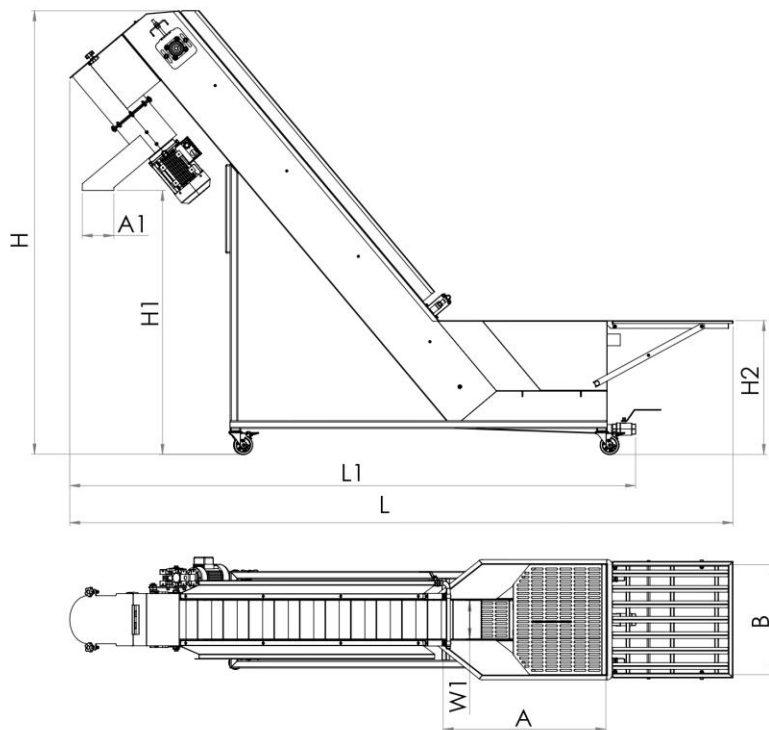

control panel.

- Optional replaceable cutting graters/sieves are available for different fruits and berries.
- The mill does not damage the fruit seed.
- The machine is easy to clean after using.
- Powerful 2.2 kW crushing engine can crush various fruits, berries and vegetables – from soft raspberries to hard apples, beets, etc.
- The machine is entirely made of stainless steel.
- Same bigger efficiency machine [MAXIMILL 3000](#)



	Machine	Fruit and vegetable washer-elevator-grinder
	Type	Maximill 1000

Output	kg/h	1000
L	mm	3440
L1	mm	2935
W	mm	630
W1	mm	200
H	mm	2300
H1	mm	1370
H2	mm	700
AxB	mm	840x570
A1xB1	mm	165x205
Dry weight	kg	195
Supply source	kW	3.0
Supply voltage	V	3/N/PE ~ 400 V 50Hz



Belt press **POWERPRESS 400** is designed for pressing fruit, berry and vegetable mass. Fruit mass is placed on the belt which presses it against cylinders.

The obtained juice flows into integrated collection tank under the press. Then the pump transfers the juice from the press to a desired tank for further processing. The pressing process is continuous.

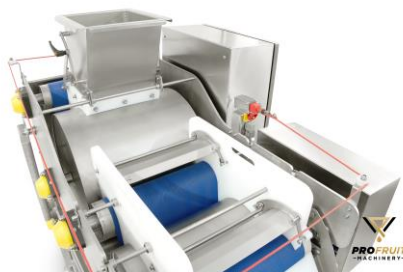

- The most evolutionary feature of our Belt press POWERPRESS line is that belt presses come with integrated pump and juice collection tank. This means you save money and do not need additional juice collection tank and pump which otherwise would use much space and cause additional costs.
- The juice yield of apples using our belt press is ~75 %.
- There is a filtration sieve integrated into the juice collection tank. Because of that the belt press 400 filtrates the juice even during the pressing stage providing cleaner and more pure product.
- The belt presses work automatically: when the mash inlet tank is full, all other machines, which come before belt press, turn off automatically. When the juice tank is full, the pump automatically pumps the juice into the tanks.
- The belt press includes a high-pressure washer, which continuously washes the belt of the machine. Our belt washing system is simple, does not contain any engines or reducers, so it prolongs the use time and saves the

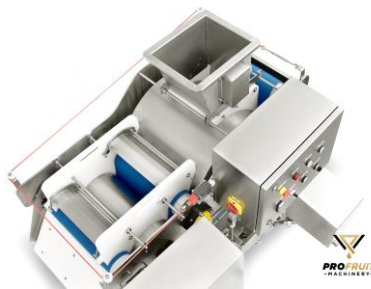

- service costs.
- After work, belt press should be manually washed with a water stream. A full washing process takes around 15-20 minutes. Washing is simple and all the parts of the belt press are easily removable without any tools.
  - Belt tension is adjustable.
  - Machine is made entirely of stainless steel and has adjustable feet.
  - Easy to clean with no closed or inaccessible spaces, all parts are easy to assemble
  - Different efficiency [POWERPRESS 800](#), [POWERPRESS 1200](#), [POWERPRESS 1500](#)

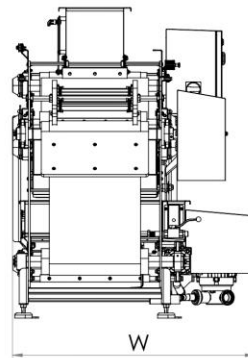
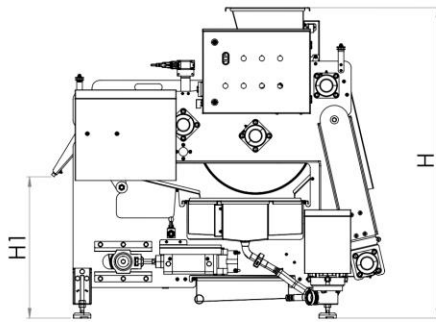

Output	kg/h	400
L	mm	1465
W	mm	1065
H	mm	1340
H1	mm	600
T	mm	400
AxB	mm	315x250
Supply source	kW	1.1 kW
Supply voltage	V	3/N/PE ~ 400 V 50Hz

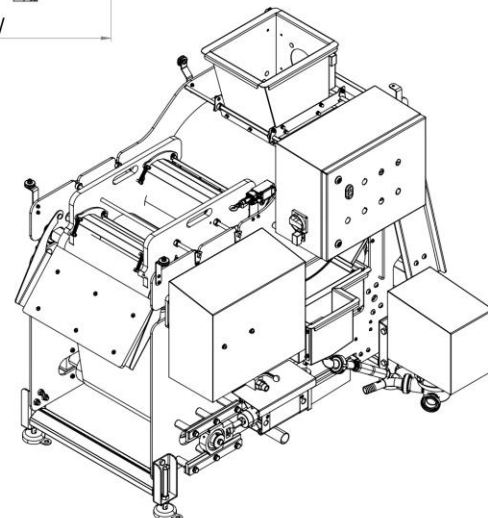
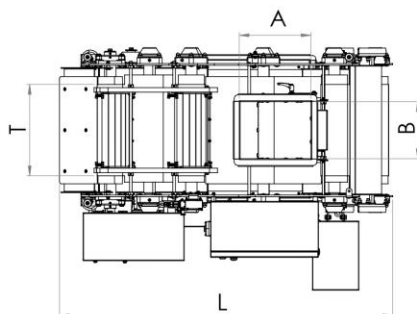

	Machine	Belt press
	Type	POWERPRESS 400

**Screw conveyor** is used to transport a leftover mash from press.

The leftover fruit, berry or vegetable mash enters the loading hopper of the screw conveyor.

The screw inside the machine is continuously turning and this way transports the mash from the loading hopper to the exit outlet at the top of the machine. The mash exits the machine.

- Screw conveyor is made of stainless steel.
- Machine has a closed tunnel.
- Conveniently transports leftover pressed mash from press.



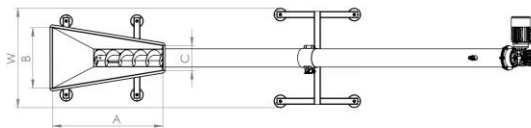
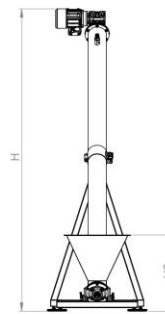
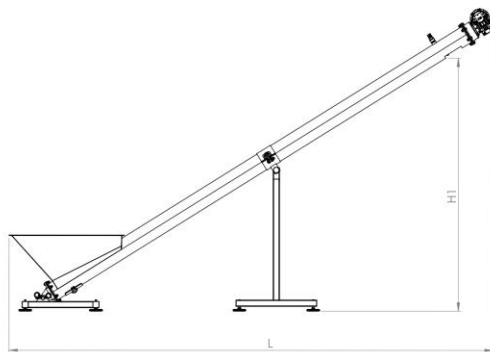
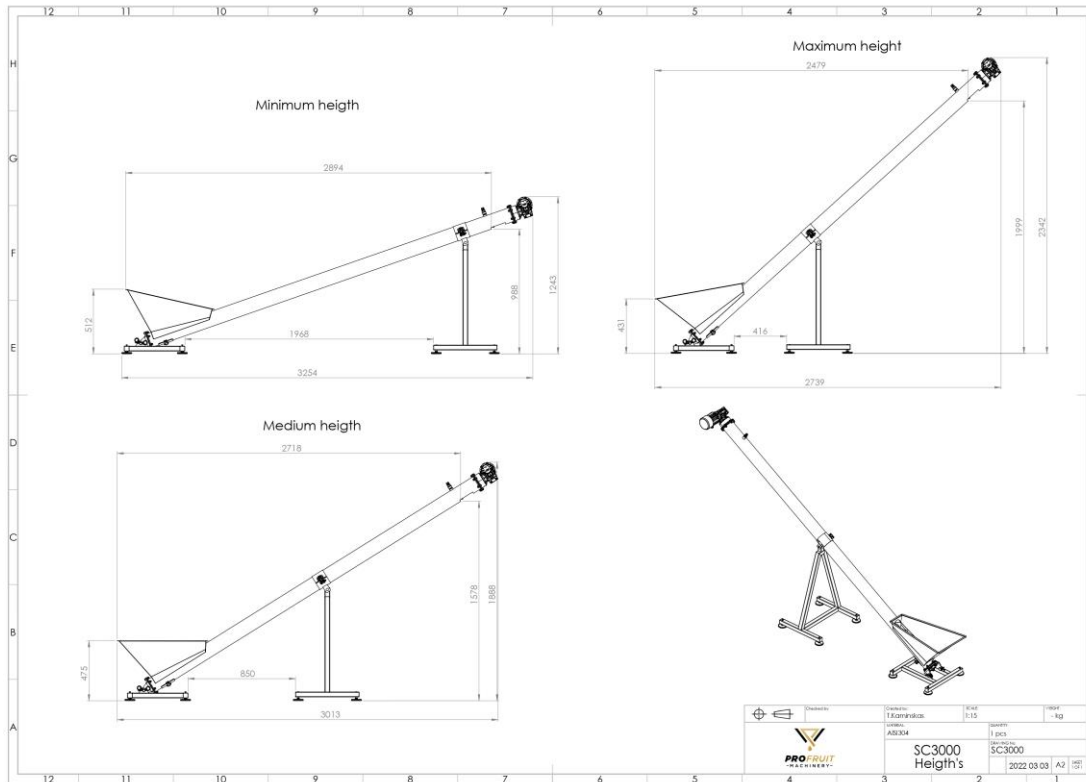

Type	SC3	SC4	SC4.5
L, mm	3013	3945	4358
H, mm	1891	2461	2725
W, mm	620	620	620
Output kg/h	1700	1700	1700
H2, mm	440	440	440
AxBxC, mm	685x377x156	685x377x156	685x377x156
Supply source, kW	0.4	0.4	0.4
Supply voltage, V	3/N/PE - 400 V 50Hz	3/N/PE - 400 V 50Hz	3/N/PE - 400 V 50Hz

	Machine	Screw Conveyor for Pressed Mash
	Type	SC3000, SC4000, SC4500

**Mechanical double juice filters** provide filtration of juice before pasteurizing.

Mechanical double juice filters are made of stainless steel. The set includes two parallel stainless-steel filters that can work separately one from each other. The double juice filters filtrate the juice and eliminate various thick particles in it. This provides particularly clean juice. The valves of the filters can also be shut off separately during the washing process or for other purposes.

- Available mesh: 60 µm, 200 µm, 300 µm, 400 µm, 500 µm.
- Connection D25.
- Capacity: 2000 L/h.
- Stainless steel ensures longevity as well as quality of the product.
- Stainless steel filters are easy to clean after using.



**Diesel/gas pasteurizer HEAT 500** heats up the liquid before the filling process. The liquid comes into the tubular spiral which is surrounded by hot water. The heat from the water heats up the liquid and eliminates the bacteria.

One of our highest machinery achievements is our energy-saving solution integrated into our pasteurizers. It saves the heating energy up to 15-20 % and results in incredibly low heating costs. Calculations show that it costs up to 2 Euro Cents to pasteurize 1 liter of liquid.

Capacity per hour – 400-600 L of 80 °C (176 °F) heated juice.



- The pasteurizer is suitable to heat various liquids, including viscous liquids: juice, puree, wine, broth, milk and other.
- The maximum heating temperature of diesel pasteurizer is 90 °C (194 °F).
- Our pasteurizers are equipped with highest quality German diesel and gas burners GIERSCH.
- The heating power is 53 kW.
- Pasteurizers' heating chambers are covered with special heat-insulating paint which preserves high temperature for a longer time and increases heating capacity.
- Diesel/gas pasteurizer has a digital thermostat which provides an automatic water temperature control.
- Automatic regulation of juice temperature ensures an easy way to change the filling temperature on digital display.
- The pasteurizer is fast and easy to clean. It can be washed by CIP cleaning together with our Bag in Box fillers.
- Machine can use diesel or gas on client's request.





- The boiler has an integrated spiral. This provides saving of space and also prevention of heat loss when pumping the water into external heat exchanger. As a result, this technology saves the heating energy up to 15-20%.
- Diesel/gas pasteurizer has pivoting wheels.

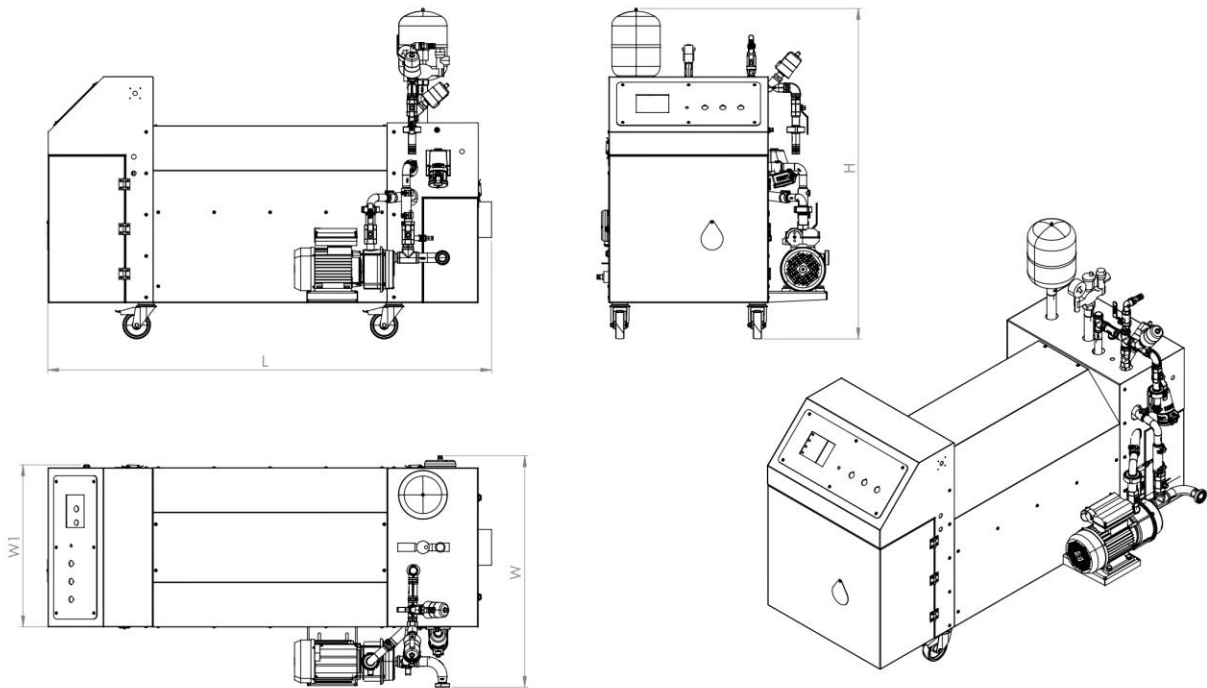

	Machine	Diesel Pasteurizer
	Type	HEAT 500

L	mm	1600
W	mm	840
W1	mm	590
H	mm	1200
Capacity	l/h	400 - 600
Max heating temp.	C	90
Fuel consumption	l/h	5-7
Supply source	kW	1.1
Supply voltage	V	3/N/PE ~ 400 V 50Hz

**SEMIFLOW** fills packages automatically. Just insert the bag or pouch into the Bag in Box filler and pull the handle. After the package is filled, return the filling handle into start position and cap the bag.



- Perfect for filling various liquids: from juice, wine, milk to broth, oil, soap, etc.
- Fills Bag in Box bags in sizes 1–30 L, Stand up Pouch packages in sizes 0,75–5 L.
- Suitable for both hot and cold fillings.
- Machine fills both Bag in Box and Stand-up Pouch packages with a tap.
- The filler can have an optional detachable buffer tank for hot filling. It is mounted conveniently on the side of the machine for better inspection and easier washing process. The buffer tank also reduces liquid foaming during hot filling process.
- The buffer tank has an integrated liquid level control inside for regulation of overspill and level in the tank. Buffer tank also comes with a connection to our pasteurizer.
- Error of volume repeatability is just  $\pm 0,5 \%$ .
- The filler pre-vacuums the bags and pouches before filling.
- Comes with touchscreen panel and multi-language menu.
- Easy-to-adjust filling table allows easily fill different volumes of Bag in Box & Stand-up Pouch packages.
- The working surface of the table consists of conveyor rollers which are easy to clean and help for the smooth slide of the bags and pouches.
- Is easy to clean after work with external and CIP cleaning.





### Capacity:

<b>3I</b>	300 bags per hour (~1000 l/h)
<b>5I</b>	280 bags per hour (~1400 l/h)
<b>10I</b>	250 bags per hour (~2500 l/h)
<b>20I</b>	120 bags per hour (~2400 l/h)

