

PROFRUIT MACHINERY

Official Manual & Instruction Document

Fruit and Vegetable Washer

AQUA 3000

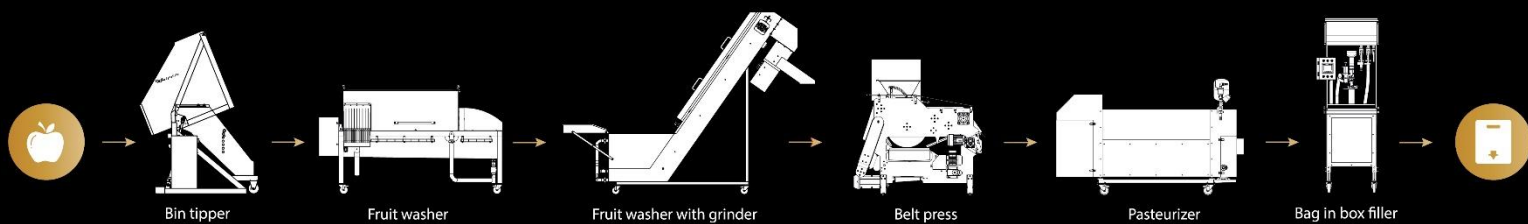

INFORMATION ABOUT MANUFACTURER

Manufacturer: UAB ProFruit Machinery

Representator: director Pijus Lopata

Address: Razes g. 27, Peskojai v., LT-92385 Klaipėda county, Lithuania

Company code: 305202037

VAT codee: LT100012484812

E-mail address: info@pro-fruit.com

Website: www.pro-fruit.com

Warning signs

There are special warning and prohibition signs put on the machines which are meant to inform the user about danger and keep everyone – people and machinery – safe at all situations. The meaning of each sign is described below.

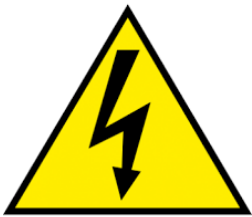

**Control console.
High voltage**



Headers required



Work shoes required



The risk of limb injury.

It is mandatory to remain alert and protect the limbs.



The risk of limb injury.

Moving parts of the machine.



**Hot surface.
Risk of getting burned.**



**Warning. Sharp parts of machine
Risk of limb injury.**

GENERAL REQUIREMENTS

General machinery using instructions:

- Ambient air temperature +8...+35° C.
- Relative humidity (when temperature +25 °C) iki 70%.
- Atmospheric pressure, kPa 84-107.
- The Law on Occupational Safety and Health of the Republic of Lithuania, the General Provisions and Safety Instructions for the Use of Work Equipment and the Laws on Occupational Safety and Health of the European Union must be observed while using the machine.

Fruit and Vegetable Washer AQUA 3000

Fruit and vegetable washer AQUA 3000 is designed for washing and cleaning fruits and vegetables before processing. Fresh water and soft brushes leave the product intact, wash gently and cleanly.

- Capacity – 3000 kg/h.
- Fruit washer - contact surfaces are constructed from stainless steel or food-grade materials.
- Mounted on pivoting wheels.
- Easy cleaning of the washer after use.
- Washer cover can be opened for inspection and cleaning.
- Operation at the central command box.
- The speed of the washer is adjustable – the speed of the fruit washer dictates the capacity of the whole processing line.
- Gradual exchange of water during the washing: the inflow of fresh water comes in at the entrance of the washer, the outflow of the waste water goes out through the small tube at the entrance the washer, and excess of the water goes out at the exit of the washer.
- Long slide at the outlet for draining fruits and removal of dirt (e.g. leaves, branches, etc.).

Attention! It is mandatory to wash off the device before starting it for the first time.

It is important to eliminate any manufacturing residues and the dust which has built up on the surface, taking care not to wet the electrical parts and keeping the power supply cable disconnected.

Machinery specification and drawings:

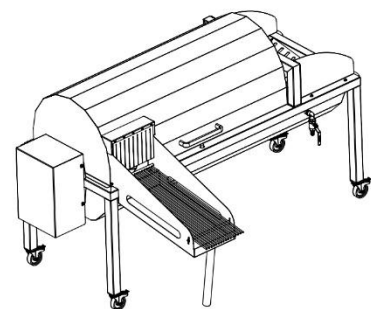
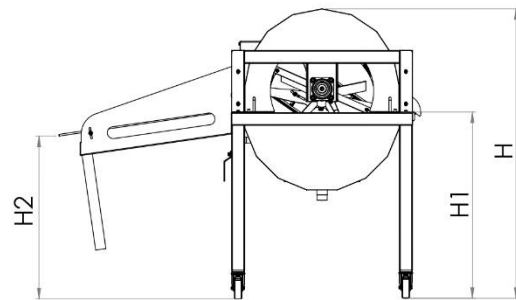
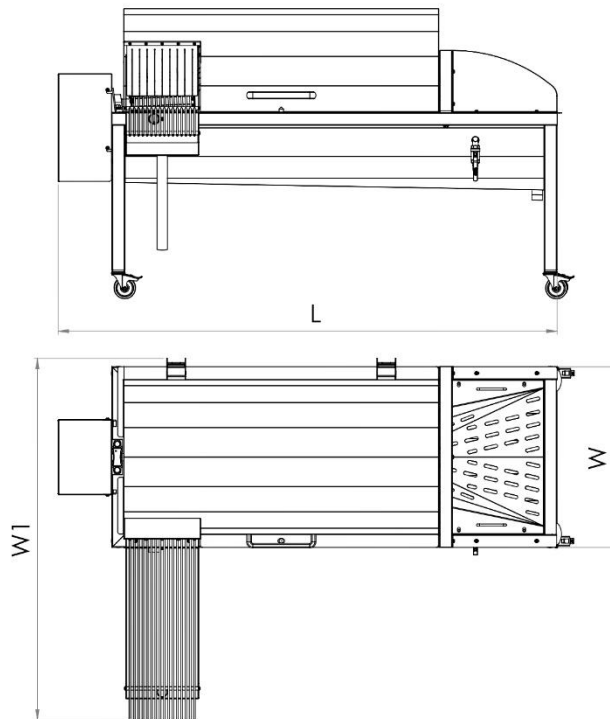

	Machine	Fruit and vegetable washer
	Type	AQUA-3000

Output	kg/h	3000
L	mm	2320
W	mm	840
W1	mm	1682
H	mm	1345
H1	mm	865
H2	mm	725-780
Weight	kg	270
Supply source	kW	0.8
Supply voltage	V	3/N/PE ~ 400 V 50Hz



1.	Product inlet
2.	Product outlet
3.	Tray for water, leaves, etc.
4.	Washing brushes
5.	Pivoting wheels
6.	Water supply inlet
7.	Cover lid
8.	Water exit outlet
9.	Water excess outlet
10.	Control cabinet

Assembly, connection and installation of the machine

Steps to accomplish in order to start working with the machine:

- Connect a water hose to the water supply valve.
- Fill the washer with water until the water reaches the washing brushes.
- Connect power cable to the three-phase connection.

The main instruction of central control box

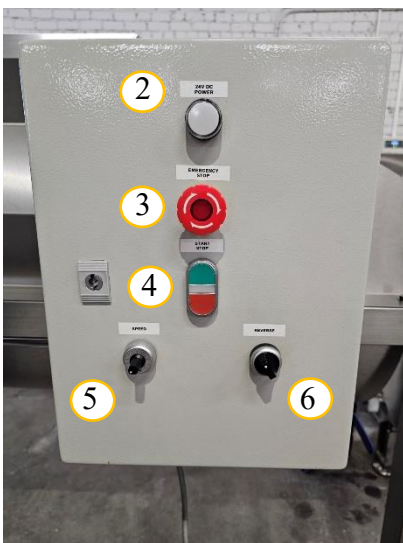

- Control the switch **Nr. 1** to turn the machine on or off. Horizontal position (0) means the machine is off, vertical position (I) means the machine is on.
- The button **No. 2** (24VDC) is lit when the machine operates normally.
- To start or stop the process adjust the buttons **Nr. 4** – green stands for START, red – for STOP.
- The speed of brush spinning can be changed using adjusting wheel **No. 5**.
- In case of emergency or in need of immediate stop press a button EMERGENCY STOP **No. 3**. To turn this button off you need to pull the button.
- To adjust set the turning in reverse, use a turning switch **No. 8**

Instructions for using the machine

The machine works when its power cable is connected and machine is started on control cabinet. No additional machine management is required. If the client desires additional control functions, the manufacturer can implement them according to the requirements.

Safety mechanisms

- **Emergency switch No. 1 EMERGENCY STOP** – needs to be pressed in case of emergency to immediately stop the machine.
- **Cover lid of the washer** – the washing screw of the machine has a protective cover lid with a mounting screw. When machine is the working mode, this cover lid must be closed and secured with the mounting screw at all times. It is prohibited to use the machine until the cover lid is closed and secured.
- **Safety in case of a sudden black-out** – when the power supply is suddenly cut off or a similar situation happens the machine is turned on normally and does not cause any dangerous situations like sudden start or improper operation.
- **Safety break** – machine is mounted on stable and pivoting wheels with breaks. The breaks are fixed with the help of the foot.

- **Safety of electronical pieces** – all the electronical pieces are installed in the internal part of the central command box and shielded with the protection lid. The lid can be opened only with a special key.

Workplace of an operator

- The machinery is operated by one person.
- The workplace of an operator changes.
- When the fruit and vegetables are being filled into the washing – the operator works in front of the machine near the fruit tray.
- When fruits and vegetables leave the machine and spoiled products need to be picked out – the operator works at the exit of the machine near to the tray for product selection.

Washing process

- Fruits and vegetables enter the washer through the entrance of the products.
- Washer rotates the products through the tub filled with water.
- Brushes inside the tub washes off all dirt from products.
- The water outlets and inlets provide clean water circulation during the working process.
- Cleaned fruits and vegetables exit the machine and enter the tray for further product selection.

The washing of machine

- Wash the machine with a water stream only when machine is turned off.
- Remove the product inlet lid for easier washing.
- It is recommended to wash the whole machine with a water stream except the engines and bearings.
- It is forbidden to wash or spray any liquids onto the engines.

Conditions for using the machine

- A higher than 1,6 m room or using area is required.
- The area around the machine needs to be empty so machine would not be bothered with any interference.

- The machine, its workplace and ground must be kept clean, neat and properly lit at all times when using it.
- The machine is operated by one person who has passed his training with the machine and is familiar with all the instructions and risks.
- Flat, stable and solid ground is needed for machine, the ground must hold 400 kg weight. This stable ground is always obligatory: when using the machine, during transportation, assembly, dismantling, testing, foreseeable failure or non-usage periods.
- When transporting, lifting or storing the machinery the client is obligated to assure its safety and proper fastening.

Safety requirements

- If some machinery failure, obstacle, accident, emergency or any other dangerous situation happens it is obligatory to stop, shut down the machinery immediately or operate equipment depending on the situation in order to avoid or eliminate dangers.
- The machinery can be operated only by person who has passed his training for machinery and is familiar with all the machinery instructions and risks. The person also must be in proper physical and mental state and not be affected by any substances that could interfere with normal functioning (such as pharmaceuticals, drugs, alcohol etc.).
- It is prohibited to do any activity with the machine during its working process (such as washing, transporting etc.).
- It is prohibited to wet or pour any liquids onto the electric cabinet.
- Every time before using the machine the operator must carefully inspect the machine, check if all the parts and electrical buttons are in place and working properly as well as examine if the equipment meets all the safety requirements and is prepared for normal work.
- The engines can be fixed, repaired or changed only by the manufacturer or its approved repairing company. All the engineering and electrical works must also be performed by the manufacturer or its approved repairing company.

Warnings

- It is prohibited to put products or things into the machine that could damage or cause any harm to it. Only products that can be identified as fruits or vegetables can be used with this machine. Berries are not suitable to use in this machine.
- It is prohibited to wash and process berries, fruits and vegetables that could clog, stop or improperly aggravate the work or harm the machine and its parts in any way (such as tomatoes, watermelons, peaches, strawberries, etc.).
- It is forbidden for any people to touch, lean on or have contact in any way with the working machine, its parts, the products that are being washed or other dangerous parts because of the risk of injury. Only actions that are necessary for a proper work with the machine are allowed.
- All machinery parts, buttons and operational details must be used according to their purpose.
- Any arbitrary adjustment, repair or other mechanical modification of the machine by a non-manufacturer will result in termination of the warranty service.
- It is always prohibited to climb or put things on the machine.
- The machine only works properly when all its parts are properly attached.
- The machine can only be washed, lifted, transported or otherwise operated after it was switched off completely.
- The cover of the engine and central control panel is opened with a special key by an operator or warranty service person.
- Maintenance of the machine must only be carried out by the manufacturer or its approved company.
- The manufacturer produces and prepares the machine based on all machinery requirements and the client's needs. Changing and mechanically adjusting any machinery settings without manufacturer or its approval is prohibited.
- If the client notices any defect, failure or other unwanted interference, he is obliged to inform the manufacturer within 5 working days regarding guarantee service or other solution for the problem.

Residual risks

- In compliance with all safety requirements, there a risk of sound and hearing damage due to the noise and vibration of the device (depending on the load), water splashes and possibility of getting wet still remain.

Precautionary directions

- Before using the machine, the operator must inspect the machine for defects and meet all safety requirements. If discrepancies are found, do not use the machine until they have been eliminated.
- It is recommended to remain attentive around the machine and to keep a distance from the machine and its washing and crushing parts when it is not necessary.
- If the situation requires contact with parts of machinery that are hazardous to health or dangerous to environment, additional precautions must be taken: consultation with the manufacturer, usage of other equipment or tools, wearing protective gloves and other actions depending on the situation.
- It is recommended to wear clothing and footwear that is non-slip, water resistant and is appropriate for work.
- It is recommended to follow all the safety requirements depending on the products and the way how operator chooses to put them into machine (to not lift products that are too heavy by yourself, to carefully put them into the machine and work while protecting your health).

Transportation of machine

- The machine is transported by a truck.
- The machine is transported in one piece without separating its parts.
- During transportation the machine must be secured in such a way that its components are not damaged and the machine itself remains stable during transport.
- When transporting and otherwise moving or changing the position of the machine it must be done after it had been completely switched off, emptied and securely fastened.
- The machine must be put straight during transportation.

Operation of the machine in case of risk

- In the event of an accident or emergency operate the machine depending on the situation: stop, shut it down, return to a safe or less dangerous position immediately and eliminate the danger.

- If the machine breaks down, switch off the machine and evaluate the failure. If the failure cannot be eliminated by yourself (such as removing the dirt, other obstacles) or it is dangerous, contact the manufacturer for warranty service, if the warranty service has expired, apply for repair.
- In case of jammed machine assess the situation, inspect the jammed part of the machine and try to solve it if there is no danger. Depending on the situation try restarting the machine or contacting the manufacturer for warranty service or repair.

Adjustment and maintenance of machine

- Inspect machine parts (washing parts and mill) before every use, regularly check machinery.
- Wash the machine regularly (after each shift).

Troubleshooting

- Troubleshooting must only be carried out by an authorized and qualified person, with the right and appropriate skills and training for the job.

Disturbances / error	Possible reason(s)	Remedy
Machine does not function	Phase missing Phase swapped	Have an electrician to check this
Machine does not function	EMERGENCY SWITCH pressed	Unlock EMERGENCY switch
Machine not starting	Thermal relay is activated.	Make sure that machine is not stuck, there is no obstacles for machine to work. Open the control cabinet and unpress thermal relay button.